



**plantforce**

[plantforce.com](https://www.plantforce.com)

“ Whilst experience and service is key, we also look to the future. Our progress with machine control technology, people – plant interface and telematic reporting has seen the company reach new limits regarding innovation and enhanced customer fulfilment.”



# One Brand. One Team. One Plantforce.

Plantforce are a national supplier of technologically advanced plant hire machinery tailored to the construction, rail, major project and energy industries.

## Who we are

Established in 1999, we have grown year on year to now provide one of the largest and most diverse ranges of machinery and skilled operators in the UK. With divisions such as Plantforce Compact, Attachments, Digital and Crushing and Screening, we are able to meet industry needs, with industry specific equipment.

While expansion has seen us grow nationally and provide plant from the top of Scotland to the most southern parts of Cornwall, we have kept the companies tradition of servicing all projects with the same attention to detail.

Building our business around the needs of our customers has given us the foundation to service major developments, such as the construction of the Hinkley Point Nuclear Power Station. This project was Europe's largest construction site and we are proud to support its progress, having been principle supplier for over 9 years, we have had more than 300 items of plant on hire and over 200 working personnel onsite at peak times. It has given us valuable experience which we are able to pass on to every client when they choose us.

“A company is only as good as its people”

Sam Mercer - Chief Executive Officer





# Our People

People are the heart of our business. This is why we place such a strong emphasis on creating the right working culture. One that's based on a collective respect for ethics and principles, where you're encouraged to really make the most of your talents in a supportive environment.



**Community  
Engagement**



**Developing  
Our People**



**Mental Health  
Awareness**

## Our Leadership Team



**Sam Mercer**  
Chief Executive Officer



**Charles Murphy**  
Chief Financial Officer



**Chris Matthew**  
Commercial Director



**Claire Trott**  
Founder Executive  
Director



**Jane Gibbons**  
Operations Director



*“ Since my first day, Claire has always said that “any business is only as good as its people”. This has stuck with me, and when I look around the team at Plantforce, I can see how that has been embedded into our culture. With members of the team like Chris Bruce (Sales Director) that have been with us for all 25 years and over, we are very lucky to have a large percentage of long-serving staff. Something that is no mean feat when you look at the huge changes we have gone through to transform from our humble beginnings in a muddy yard in Yatton to the national player we are today. None of this would have been possible without the hard work and dedication of our team, whose ability to adapt and overcome always astounds me.*

*Although we have always held our family-run business ethos close to our hearts, as a collective, we have an astute recognition that our teams’ individuality is what sets us apart. As a business with a diverse leadership team, we always have and will continue to understand the challenges people in all minorities face and will strive to offer both an inclusive environment within our business, but also open the doors to the rest of the industry. The perfect example is our apprenticeship programme, which continues to provide a gateway to the industry for all, regardless of age, ethnicity, gender, sexual orientation or any other factor that could discriminate.”*

**Sam Mercer**



# Operator Solutions

---

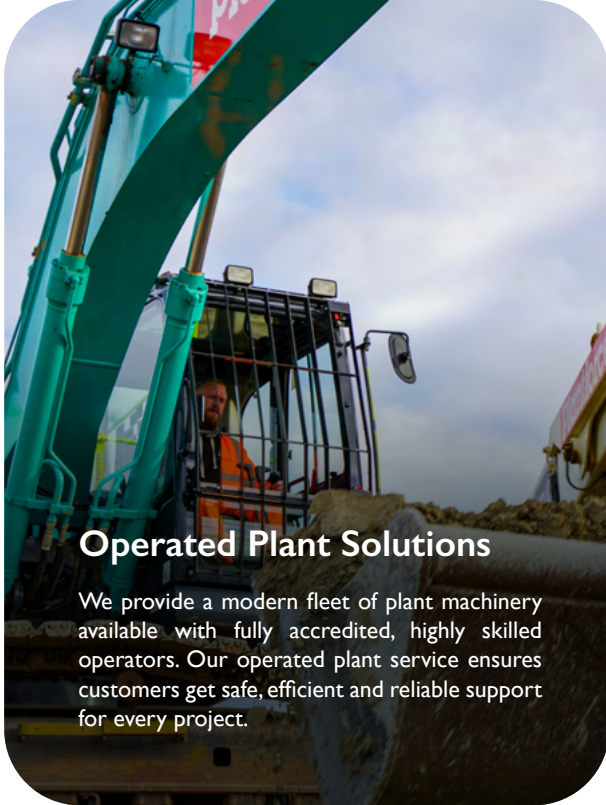

## Operated Plant Solutions

We provide a modern fleet of plant machinery available with fully accredited, highly skilled operators. Our operated plant service ensures customers get safe, efficient and reliable support for every project.

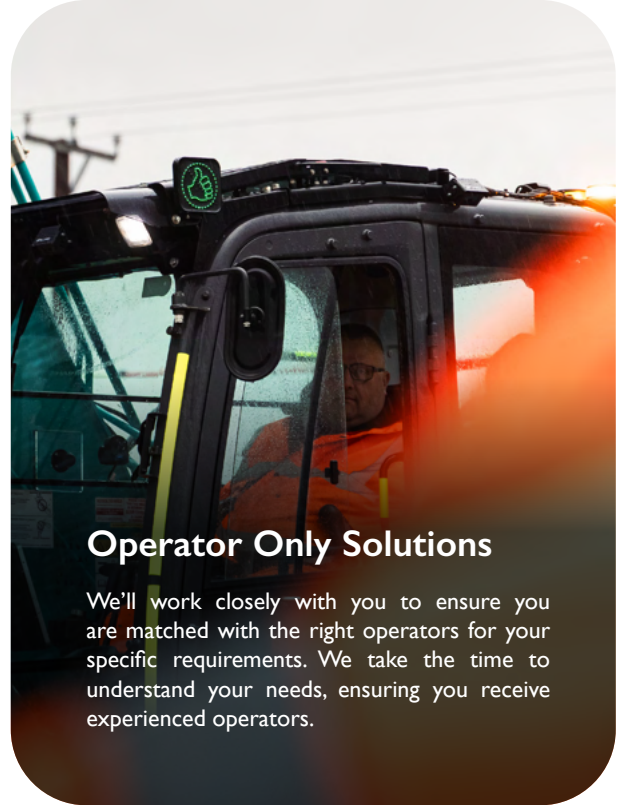

## Operator Only Solutions

We'll work closely with you to ensure you are matched with the right operators for your specific requirements. We take the time to understand your needs, ensuring you receive experienced operators.



## Qualified Operators Across The UK

At Plantforce, we have one of the largest and most diverse ranges of machinery in the UK. Our team of qualified engineers perform rigorous checks, both pre and post hire to ensure that our machines arrive in the best possible condition. We also have a proactive complaints process, which is very much a collaborative approach to dealing with any issues that might arise.



# Looking for Qualified Operators you can Trust?

## 6,000 + Operators

Get instant access to 6,000+ fully qualified, vetted plant operators across the UK.

## Accredited to match project needs

At Plantforce, we supply CPCs, CCNSG, PTS and RISQS accredited operators matched to your project needs, backed by a modern fleet and fast mobilisation.

## Full Nationwide Coverage

Our UK-wide operator database gives you full visibility of skills, certifications and past performance, so you always get the right person for the job.

## Essential information available online

All documentation is available instantly through the Plantforce Operator Portal, keeping your team compliant and your project moving.



Ashleigh Jones  
National Recruitment Manager

Find out more [here](#)



# Operator Solutions

Why Choose Operated Plant Hire With Us?

## Solutions for Specific Industries

We supply fully PTS-accredited operators for specialist sectors such as rail, ensuring every project is supported by professionals who understand the unique demands and strict safety standards of these environments. Our operators combine industry expertise with advanced training, giving customers complete confidence in safe, compliant and efficient delivery.



Find out more [here](#)

## What we have Operators for?



Tracked Excavators



Dozers



ADT's



Loading Shovels



Rollers



Site Dumpers



Wheeled Excavators



Telehandlers

## What Comes with your Hire?

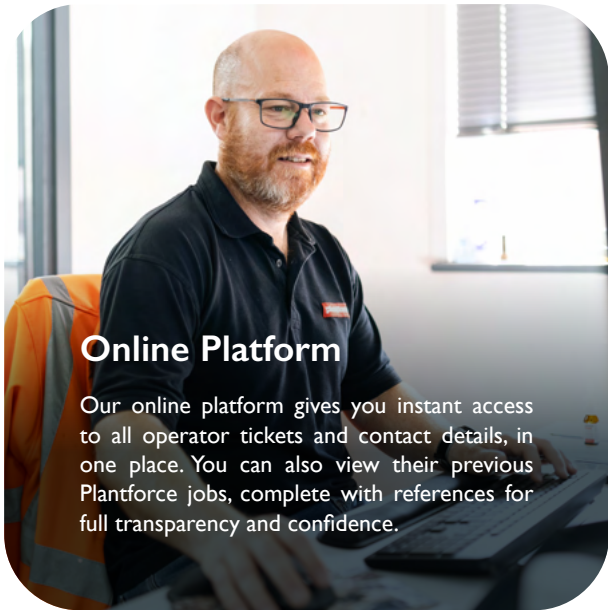

### Online Platform

Our online platform gives you instant access to all operator tickets and contact details, in one place. You can also view their previous Plantforce jobs, complete with references for full transparency and confidence.



### Operator Welfare Checks

Regular welfare checks ensure that your operator is supported, comfortable, and able to perform at their best on your project. This proactive approach helps maintain high standards on site and ensures you are happy.

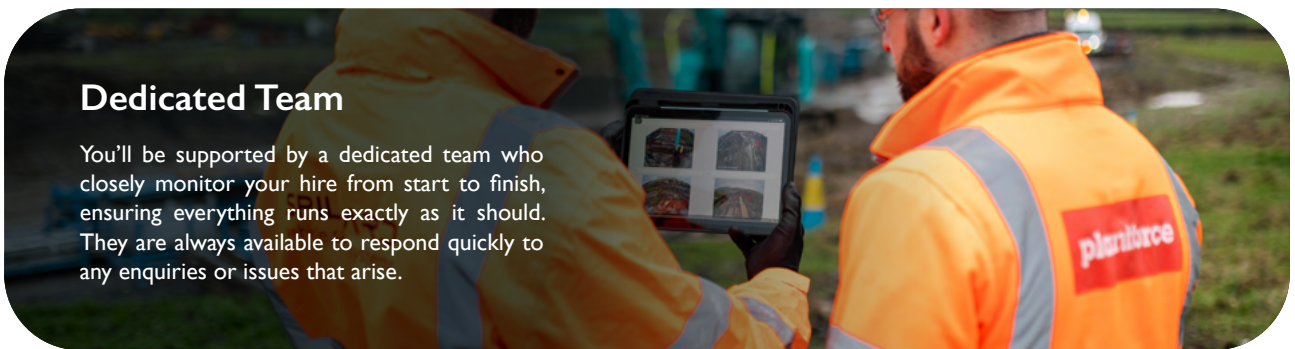

### Dedicated Team

You'll be supported by a dedicated team who closely monitor your hire from start to finish, ensuring everything runs exactly as it should. They are always available to respond quickly to any enquiries or issues that arise.

---

## Meet the Operator Recruitment Team



**Ashleigh Jones**  
National Recruitment  
Manager



**Andrew Miller**  
Resourcing  
Co-ordinator

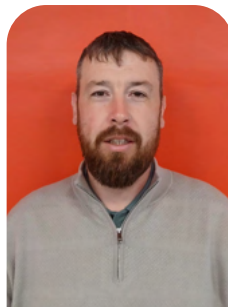

**Alex Hammocks**  
Resourcer  
Midlands



**Ben Keeler**  
Operator Assessor



**Mike MacDonald**  
Operator Assessor  
East / Sizewell



# Innovation

SevernNet Business Breakfast Meeting

## Leading The Construction Industry Towards A Zero Emissions Future

Plantforce is a partner in the Element 1 project. Funded by the UK Government Department for Energy Security and Net Zero, this initiative introduces hydrogen as a cleaner fuel to reduce diesel use in heavy off-highway equipment on construction sites. By adapting engines to run on 30-50% hydrogen, this project will test the feasibility of rolling out hybrid hydrogen-diesel engines to existing machines, which will cut emissions without replacing machinery, avoiding unnecessary waste.

Over the project duration, the project partners will showcase these solutions on live construction sites, demonstrating hydrogen's role in reducing fossil fuel reliance. The design and demonstration of an end-to-end solution for the manufacture, supply, distribution, storage and use of hydrogen as a fuel are all included within the project scope.



Thornhills Beck Lane Kobelco Deployment



Element | Meeting - London

Victoria North - 1st Deployment





# Sustainability

## Sustainability at our Core

At Plantforce, we are dedicated to reducing our environmental footprint across all areas of our operations. Recognising our role within a larger ecosystem, we embrace our responsibility to protect and preserve the environment.

This commitment is evident in our focus on sustainability, our investments in advanced fleet technology, and our comprehensive training programs.



**Net Zero  
carbon emissions  
by 2045**



**Reduce carbon  
emissions to 50% of  
2021 levels by 2030**



**Reduce carbon intensity  
to 50% of 2021  
levels by 2030**

## Our Commitment

Sustainability starts from within. We are committed to continuously improving our operations, reducing waste, and transitioning to cleaner, more efficient solutions. Through, but not limited to, the following initiatives:

- ✔ **Electric & Fuel-Efficient Company Vehicles**
- ✔ **Improvement of Operational Efficiency**
- ✔ **Waste Reduction & Recycling**
- ✔ **Environmental Impact-Driven Fleet Procurement Strategy**

By taking responsibility for our own environmental impact, we are setting new standards for sustainability in our industry.



# Our Sustainability Strategy

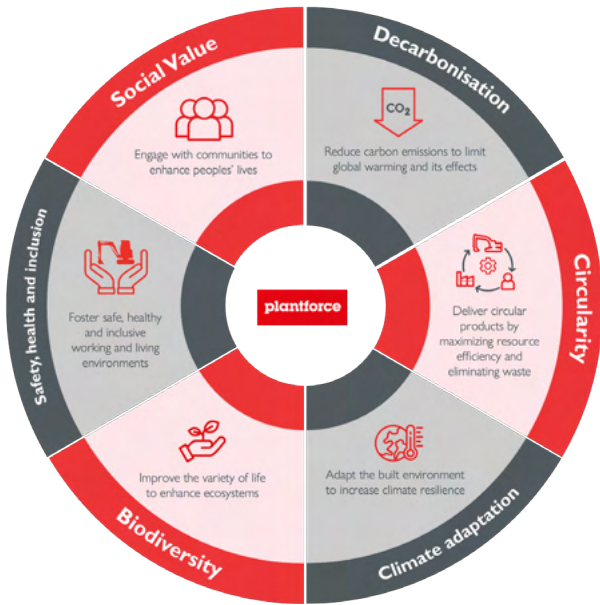

## Decarbonisation

Reduce carbon emissions to limit global warming and its effects.

## Circularity

Deliver circular products by maximising resource efficiency and eliminating waste.

## Climate adaptation

Adapt the built environment to increase climate resilience.

## Biodiversity

Improve the variety of life to enhance ecosystems.

## Safety, health and inclusion

Foster safe, healthy and inclusive working and living environments.

## Social value

Engage with communities to enhance peoples' lives.

## Fleet Investment Strategy

Through our forward-thinking fleet investment strategy, we're adopting cleaner, more efficient technologies that align with our vision of a greener tomorrow.

- Focus On Fuel Efficiency
- Adopt New Technology
- Investment In Diesel Replacement Technology
- Low-Age Profile Fleet Renewal

## Industry Collaboration

We believe in the power of partnership to drive change. By working closely with industry leaders, we innovate solutions that not only meet today's needs but also anticipate the demands of tomorrow. Together, we're redefining what's possible in sustainability.



### First Deployment Of The Dual-Fuel Hydrogen Excavator



# Advanced Safety Solutions

## Human Form Recognition Cameras

Alert the operator when people are approaching the working radius of their machine. By working with industry-leading manufacturers and investing in the latest technology, Plantforce can offer you a human form recognition camera system that meets your needs.



## Trusted Human Form Experts



Find out more [here](#)



## Trusted Safety Partners





## AI-driven HFRCS cuts red zone incursions by over 50%

Click below to watch the video explaining how our successful trial with Spillard vehicle safety systems and their new integrated managed solution, which uses a mix of AI and a dedicated account manager to categorise incursions, has helped them reduce potential accidents by over 50%.



[View the video here](#)



## Advanced Safety Technologies & Systems

Our advanced safety technologies are designed to enhance situational awareness, prevent collisions, and ensure compliance with industry safety standards.

Whether it's preventing hazardous interactions with 3DAvoidance Zone Systems, or using Human Form Recognition Cameras to monitor pedestrian proximity, our solutions empower operators with instant feedback and automated safeguards to eliminate risks before they become incidents.

Physical safety systems provide the first line of defence in protecting operators and site personnel, reducing human error and enforcing best practices on-site. All machines are equipped with excavator check valves, ensuring controlled hydraulic flow to prevent unintended movement and enhance operational safety.

By integrating these durable, site-ready safety solutions, businesses can reinforce workplace safety standards, enhance compliance, and create a more secure working environment for everyone.



## People-Plant Interface Training

We are committed to ensuring the safety of our staff and external operators by providing comprehensive People-Plant Interface (PPI) training. This training equips individuals with the knowledge and skills needed to safely navigate environments where people and machinery interact, minimising risks and enhancing workplace safety.



## Our Safety Technologies & Systems



### Keypad Immobiliser

Keypad immobilisers prevent unauthorised use of heavy machinery by requiring a secure PIN code, enhancing equipment security and preventing misuse.



### 3D Avoidance Zone Systems

We offer Leica and XWatch 3D avoidance zone systems, which utilise real-time geofencing and sensor-based monitoring to establish exclusion zones, to avoid operating in hazardous areas.



### Hydraulic Quick Hitch

Secure attachment system ensuring that buckets and tools are properly locked in place, reducing the risk of dropped loads.



### Slew Restrictions

We offer XWatch and Prolec systems, providing solutions that limit the machine's rotational movement to prevent collisions with nearby hazards, structures, or workers within a defined area.



### Height Restrictions

We provide XWatch and Prolec excavator height restriction systems to help prevent collisions with overhead obstacles, including power lines, bridges, and ceilings in confined spaces.



### Digital Thumbs Up

A digital thumbs up safety system features an external LED display that enhances the traditional hand signal. When the machine operator presses a button on a dedicated interface in the cab, the display turns green with a thumbs-up symbol, often disabling machine controls and providing an audible "approach with caution" message.

# Health & Safety



Committed to ensuring that everyone returns home safely and healthy at the end of the working day.

Here at Plantforce health and safety is our priority, whether this is ensuring the health and wellbeing of our team through medicals and welfare engagement or making certain that we are working and collaborating in the safest way possible with the help of our robust inspection and audit strategy.

Our dedicated team of health and safety professionals ensures that we operate at the highest levels of compliance and best practice. They are committed to driving our vision of continual improvement across the business, fostering a culture where safety, wellbeing, and operational excellence go hand in hand.





### Culture

Develop a proactive approach to risk reduction and prevention of accidents, injuries and ill-health by promoting the IFE process, doing regular risk assessments and audits, and encouraging employee involvement and participation.



### Competence

Develop health and safety education which inspires and empowers people to work safely, or not at all. Equal emphasis on occupational health is a pre-requisite.



### Communication

Ensure clear, consistent communications utilising a range of channels to reach all stakeholders.



### Controls

Ensure we have effective systems in place and they are adhered to consistently through our integrated business management system. Controls and systems to include the management of process risks.



### Health & Wellbeing

We focus on the workplace, our workers, and overall well-being by developing skills and capabilities that preserve, protect, and promote the health and well-being of our employees.

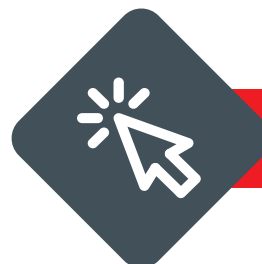

[Find out more here](#)

# Partnerships



## LP Training

LP Training Services are an experienced training provider, originally from Bridgwater, where we deliver our industry leading training and apprenticeships programme. We equip workers and clients with the skills and accreditations required for roles in Construction, Rail, and Major Infrastructure projects across the UK. Our flexible approach is accommodating and ensures the best chance of success.



View our operated plant solutions page [here](#)



View more about this partnership [here](#)

“ We continuously invest in the latest training equipment and programmes to ensure our workforce are up-skilled to meet ever updating demands of the UK construction industry.”

## Weston College

No longer do engineers use paper drawings and spray paint to mark out a road formation on the ground, or a stick to measure the fuel level in an excavator, it's all about fuel efficiency and communication systems. The excavators use telematics systems to report on fuel economy, engineers are designing buildings in cloud-based 3D CAD software which is then loaded on to the machine remotely. In the very same way

a satnav tells you where to go, the same tech is used to guide an excavator to grade, manage materials and plan work flows. Plantforce take pride in educating the future of our industry in partnership with Weston College. This approach delivers fresh talent that have been trained on the latest generation of machines and a full range of aftermarket technology solutions from leading manufacturers.



# Quality & Governance

At Plantforce, we understand the importance of providing our customers with a consistently high level of service. We strive to not only meet the expectations of our customers, but to exceed them. This is why we are committed to offering a service that our customers value, while ensuring that the same level of service is achieved each and every time. Our commitment to this is demonstrated in the accreditations we have achieved and continue to work towards.

[Find out more here](#)



## Accreditations

We maintain and develop our strong safety culture ensuring that all levels of the business are involved in health, safety and training from directorship to our operatives on the ground.

We hold regular safety meetings throughout all tiers of the business to ensure everyone's involvement.

Our qualified team are proud to have had our quality and safety management systems externally accredited to ISO 14001, ISO 45001, ISO 9001 and ISO 50001 standards.

Our commitment is reflected across the board, from the information available within the hire process to the backup and support when having to deal with site incidents.

As subscribers to the Construction Industry Training Board (CITB) and active members of the Construction Plant Association (CPA), we are always at the forefront of new developments and ensure our staff are trained in the latest techniques.





View our policies [here](#)



## Trade Associations

With one of the focuses looking at personnel satisfaction, our health and safety department aim to continually improve on our companies safety expectations.





## Community *Team*

At Plantforce, we are committed to having a positive impact in the communities where we are both based and operate.

We recognise that our company's success is linked to the health of our local communities, and so we strive to make a positive difference through our work. We are committed to engaging with our customers and local communities, to ensure our activities have a positive impact on people's lives. We also strive to provide our customers with the best possible service, so that they can benefit from our work in the local area.

We understand that our work, and the people we work with, can have a lasting and positive effect on the communities we serve.



## Social Engagement

Plantforce has an inclusive culture where differences are valued, and individuality is fully embraced. One of the ways we support this is by creating an ethos that encourages our staff to identify ways we can deliver a positive impact in the communities we operate.



Supporting local  
charities & causes



Volunteering our  
time to help others



Playing an  
active role in local  
business discussions



Supporting local  
community  
sports teams

## Supporting partnered charities



## To make a big difference



**£130,000+**  
values of donations raised so far



**500 hours+**  
volunteer hours donated by our team using their annual volunteering day allowance



**50+**  
number of unique awareness & fundraising activities completed by our team



Proud to support Community Sport Teams

# Major Projects

We are a tried and tested Tier 1 supplier

Established as a regional plant hire company in 1999, we have grown year after year to provide one of the largest and most diverse ranges of machinery and skilled operators in the UK. With divisions such as Plantforce Compact, Attachments, Digital, Heavy Haulage and Crushing & Screening, we can meet industry needs with industry-specific equipment.

Building our business around the needs of our customers has given us the foundation to service major developments, including being the only Plant Hire provider to be awarded Tier 1 status on the two largest civil engineering projects, Hinkley Point Nuclear Power Station and High Speed Rail 2.

Find out more about our involvement in these projects below:



## HS2

Plantforce secured Tier 1 supplier status for the largest earthmoving project in Europe, HS2. One of only three appointments to this status by principal contractor EKFB, Plantforce supply a full range of earthmoving equipment and digital technology solutions. With phase one of HS2 set to create 140 miles of dedicated track between London Euston and Curzon Street station in Birmingham, the project requires 22,000 workers to complete 130 million tonnes of earth to be excavated, spread over 200 construction sites. EKFB is a joint venture between major civil engineering and construction companies: Eiffage, Kier, Ferrovial and BAM.

It has been appointed by HS2 to deliver civil engineering works across an 80-kilometre section of the new high-speed rail link between the Chiltern Tunnel and Long Itchington. The section will include 15 viaducts, 6.9 kilometres of green tunnels, 22 kilometres of road diversions, 81 bridges and around 30 million cubic meters of excavation.

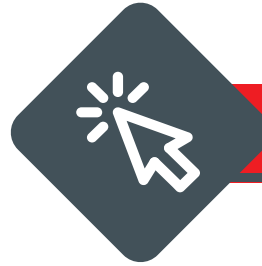

Find out more [here](#)

Hinkley Point C is the largest project that the South West has ever seen and Plantforce Rentals are very proud of the fact that we were the first Plant Hire Company to start this prestigious construction project.

Working in the nuclear industry since 2011, Plantforce have a dedicated on-site Project Manager as well as our own Health and Safety Officer.

Situated just off junction 23 of the M5 in Dunball industrial estate, Plantforce is ideally positioned next door to the new Park and Ride and Freight Management Centre for Hinkley Point C.

Fully committed on employing local labour for Hinkley Point C, Plantforce have adopted a stringent vetting process to meet the requirements needed to be able to work on a Nuclear Power Station with a particular emphasis on Health and Safety. All our fully qualified and security-cleared operators have gone through the necessary training. They also have the accreditation required to be able to work on this Nuclear Site and all our machines are compliant to Nuclear Site Health and Safety regulations. As well as a full range of excavators Plantforce also have a huge array of first class attachments available from our Bridgwater depot.

Working closely with the Somerset Chamber of Commerce and the Hinkley Supply Chain, Plantforce are an EDF Approved supplier and committed in providing a first class service with the best machinery on the market.



# Self Drive Plant Hire

## A fuel-efficient, fresh and reliable fleet at your fingertips

As the cornerstone of the Plantforce offering, our extensive fleet of excavators, dumpers, rollers, dozers and much more

for use in a wide range of applications such as construction, demolition, recycling and earthworks projects, to name a few.

## Got the team, need the machine?

Our self-drive plant hire service allows customers to utilise their own qualified operators to operate a machine hired from Plantforce and reduce the total cost of the rental.

Self-drive plant hire is available across our entire range of equipment. It is perfect for businesses that either do not want the cost of purchasing their own equipment or need a temporary increase in the number of machines.

With delivery available throughout the UK, you can get a reliable and fuel-efficient machine for your project as soon as the next day.

You have the reassurance that our fleet is backed up by our team of qualified mobile service engineers. You can trust that if there is an issue, we will promptly respond, getting you up and running again.



Need an attachment for your machine?  
Scan here



## What we do



Excavators



Dozers



ADT's



Loading Shovels



Rollers



Site Dumpers



Telehandlers



Find out more [here](#)



# Excavators



## Range Overview

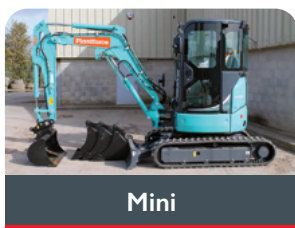

Mini



Midi

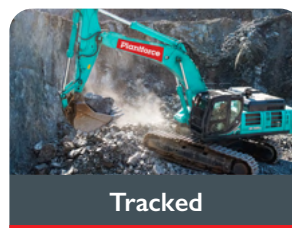

Tracked



Wheeled



Long Reach



Demolition

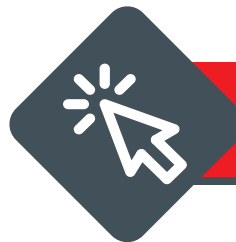

[View the full excavator range here](#)

## Mini & Midi Excavators 1t - 8t

Manufacturer	Model	Weight	Height	Length	Width	Maximum Dig Reach	Maximum Dig Depth
Kobelco	SK08	1035 kg	2200 mm	2625 mm	840 mm	2830 mm	1460 mm
Kobelco	SK10	1145 kg	2250 mm	3040 mm	1000 mm	3350 mm	2150 mm
Kobelco	SK17	1555 kg	2350 mm	3490 mm	1320 mm	3890 mm	2150 mm
Kobelco	SK25	2780 kg	2530 mm	4110 mm	1500 mm	4520 mm	2540 mm
Kobelco	SK26	2600 kg	2470 mm	4260 mm	1550 mm	5020 mm	2790 mm
Kobelco	SK34	3660 kg	2550 mm	4760 mm	1550 mm	5490 mm	2830 mm
Kobelco	SK39	4060 kg	2550 mm	4870 mm	1530 mm	5340 mm	3350 mm
Kobelco	SK50	5230 kg	2560 mm	5350 mm	1940 mm	5970 mm	3580 mm
Kobelco	SK58	5702 kg	2560 mm	5590 mm	1940 mm	6460 mm	4120 mm
Kobelco	SK75	7800 kg	2570 mm	6340 mm	2300 mm	6760 mm	4580 mm
Kobelco	SK85	8900 kg	2550 mm	6750 mm	2300 mm	7500 mm	4440 mm



Looking for an attachment?  
Scan here



Looking for GPS?  
Scan here

## Tracked Excavators | 14t - 27t

Manufacturer	Model	Weight	Height	Length	Width	Maximum Dig Reach	Maximum Dig Depth
Kobelco	SK140	14,800 kg	2,860 mm	7,500 mm	2,690 mm	8,780 mm	5,520 mm
Kobelco	SK210	22,100 kg	3,060 mm	9,600 mm	2,990 mm	9,900 mm	6,700 mm
Kobelco	SK230	22,900 kg	3,160 mm	8,830 mm	2,990 mm	9,700 mm	6,580 mm
Kobelco	SK270	26,600 kg	3,180 mm	8,970 mm	3,190 mm	9,850 mm	6,650 mm



## Tracked Excavators 30t – 85t

Manufacturer	Model	Weight	Height	Length	Width	Maximum Dig Reach	Maximum Dig Depth
Kobelco	SK300	32,800 kg	3,260 mm	10,710 mm	3,190 mm	10,860 mm	7,200 mm
Kobelco	SK350	37,800 kg	3,420 mm	11,300 mm	3,190 mm	11,060 mm	7,560 mm
Kobelco	SK500	51,200 kg	3,780 mm	12,210 mm	3,580 mm	11,690 mm	7,360 mm
Kobelco	SK500-ME	52,700 kg	4,330 mm	12,060 mm	3,580 mm	11,250 mm	6,820 mm
Kobelco	SK520	52,900 kg	3,670 mm	12,160 mm	3,460 mm	12,070 mm	7,770 mm
Kobelco	SK850	80,900 kg	4,580 mm	14,600 mm	4,440 mm	13,480 mm	8,300 mm

All our excavators are available with **multi-brand GPS, height and slew restriction systems.**



## Wheeled Excavators 10t – 18t

Manufacturer	Model	Weight	Height	Length	Width	Maximum Dig Reach	Maximum Dig Depth
Hyundai	HW100W	11,790 kg	3,011 mm	5,687 mm	2,450 mm	7,820 mm	4,245 mm
Hyundai	HW140W	14,880 kg	3,500 mm	7,760 mm	2,500 mm	8,310 mm	5,010 mm
Hyundai	HW160W	17,100 kg	3,450 mm	8,400 mm	2,500 mm	8,860 mm	5,650 mm
Hyundai	HW180W	18,360 kg	3,900 mm	8,760 mm	2,500 mm	9,200 mm	5,900 mm
Hyundai	HW210W	21,200 kg	4,020 mm	9,680 mm	2,530 mm	9,960 mm	6,380 mm

All our wheeled excavators are available with **multi-brand tiltrotators, towable trailers and onboard safety features to aid in lone man working environments.**



Find out more [here](#)

## Long Reach Excavators

Manufacturer	Model	Reach	Weight	Height	Length	Width	Maximum Dig Reach	Maximum Dig Depth
Kobelco	SK140 LR	12m	14,100 kg	2,790 mm	11,050 mm	2,590 mm	10,380 mm	4,120 mm
Kobelco	SK210	16m	23,000 kg	3,169 mm	14,569 mm	2,990 mm	14,752 mm	5,520 mm
Hyundai	HX220	16m	24,820 kg	3,280 mm	12,030 mm	15,220 mm	11,760 mm	6,700 mm
Kobelco	SK260	18m	26,600 kg	3,100 mm	9,785 mm	18,321 mm	14,752 mm	7,200 mm



## Demolition Excavators

Manufacturer	Model	Weight	Height	Length	Width	Maximum Dig Reach	Maximum Dig Depth
Kobelco	SK140	14,100 kg	2,860 mm	7,500 mm	2,590 mm	8,340 mm	5,520 mm
Kobelco	SK210	22,100 kg	3,060 mm	9,600 mm	2,990 mm	9,900 mm	6,700 mm
Kobelco	SK300	30,600 kg	3,270 mm	10,710 mm	3,190 mm	10,870 mm	7,200 mm
Kobelco	SK350	35,400 kg	3,250 mm	12,000 mm	3,340 mm	12,100 mm	7,790 mm
Kobelco	SK500	50,800 kg	3,380 mm	12,140 mm	3,350 mm	12,007 mm	7,810 mm

# Dozers



Looking for GPS?  
Scan here



Find out more [here](#)

## Dozers 9t - 38t

Manufacturer	Model	Weight	Horsepower	Blade Capacity
CAT	D3	9,362 kg	104 hp	2.19 - 2.34 m <sup>3</sup>
CAT	D4	13,272 kg	130 hp	3.26 m <sup>3</sup>
CAT	D5	19,170 kg	170 hp	3.5 - 4.0 m <sup>3</sup>
CAT	D6	23,911 kg	215 hp	3.8 - 5.8 m <sup>3</sup>
Komatsu	D6I	19,400 kg	168 hp	3.81 m <sup>3</sup>
CAT	D6TVPAT	24,733 kg	200 hp +	4.64 - 5.08 m <sup>3</sup>
Komatsu	D65	22,100 kg	220 hp	3.69 m <sup>3</sup>
Komatsu	D7I	23,100 kg	237 hp	4.65 m <sup>3</sup>
CAT	D7	29,776 kg	265 hp	7.4 m <sup>3</sup>
Komatsu	D85	28,900 kg	267 hp	7 m <sup>3</sup>
CAT	D8	38,050 kg	363 hp	10.3 m <sup>3</sup>

# Loading Shovels



## Loading Shovels 17t - 25t

Manufacturer	Model	Weight	Height	Length	Width	Bucket Capacity
Hyundai	HL960	18,800 kg	5,640 mm	8,140 mm	2,900 mm	3.4 m <sup>3</sup>
Hyundai	HL970	23,500 kg	5,970 mm	8,740 mm	3,100 mm	4.2 m <sup>3</sup>

Find out more [here](#)

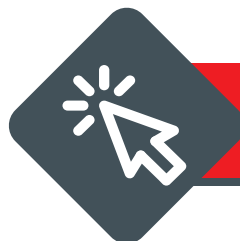
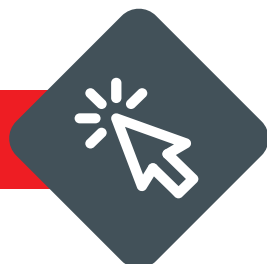

Looking for an operator?  
[Scan here](#)

# Dumpers



## Dumpers 1t - 9t

Manufacturer	Model	Weight	Height	Length	Width
Cormidi	C85	800 kg	1,500 mm	1,926 mm	810 mm
Thwaites	1t	1,225 kg	2,860 mm	3,192 mm	1,115 mm
Wacker Neuson	1t	1,261 kg	2,580 mm	3,080 mm	1,180 mm
Thwaites	3t	2,110 kg	3,092 mm	3,935 mm	1,650 mm
Wacker Neuson	3t	1,987 kg	2,969 mm	3,904 mm	1,730 mm
Thwaites	6t Straight	4,120 kg	3,300 mm	4,780 mm	2,240 mm
Thwaites	6t Swivel	4,400 kg	3,300 mm	4,780 mm	2,240 mm
Thwaites	6t Cab	4,880 kg	3,145 mm	4,815 mm	2,280 mm
Wacker Neuson	6t Duel View	4,002 kg	3,435 mm	4,448 mm	2,196 mm
Thwaites	9t	4,660 kg	3,335 mm	4,635 mm	2,440 mm
Thwaites	9t Cab	5,310 kg	3,285 mm	4,670 mm	2,485 mm
Wacker Neuson	9t Duel View	4,252 kg	3,483 mm	4,622 mm	2,420 mm



## ADTs 7t - 40t

Manufacturer	Model	Weight	Height	Length	Width
Hydrema	912	7,270 kg	2,750 mm	5,950 mm	2,490 mm
Hydrema	922	15,900 kg	3,490 mm	9,130 mm	3,240 mm
Bell	B20	16,493 kg	3,619 mm	9,271 mm	3,102 mm
Bell	B25	18,910 kg	3,454 mm	9,271 mm	2,550 mm
Bell	B30	19,216 kg	3,426 mm	9,953 mm	2,940 mm
Terex	TA300	28,000 kg	3,560 mm	9,930 mm	2,860 mm
Terex	TA400	32,233 kg	4,040 mm	11,197 mm	3,487 mm
Rokbak	RA30	28,000 kg	3,560 mm	9,930 mm	2,860 mm
Rokbak	RA40	38,000 kg	3,945 mm	11,115 mm	3,358 mm

# Telehandlers



Find out more [here](#)

## Telehandlers 4m - 17m

Manufacturer	Model	Lift Height	Operating Weight	Load
Wacker Neuson	TH412	4 m	2,750 kg	1250 kg
Dieci	25.6	5 m	4,900 kg	2600 kg
JCB	524-50	5 m	5,500 kg	2400 kg
JCB	525-60	6 m	5,490 kg	2600 kg
JCB	531-70	7 m	7,060 kg	3100 kg
JCB	540-140	14 m	10,880 kg	4000 kg
JCB	540-170	17 m	12,060 kg	4000 kg

All our Telehandlers can be hired with the following optional attachments:

- Buckets
- Lifting Hooks
- Sweepers

# Rollers



Find out more [here](#)



Looking for GPS?  
Scan [here](#)



## Rollers 1t -22t

Manufacturer	Model	Weight	Drum Width	Compaction
Ammann	ARR 1575	1,450 kg	850 mm	36 kN
Ammann	ARX12	1,475 kg	820 mm	23 kN
Ammann	ARX26	2,460 kg	1,200 mm	47 kN
Ammann	ARX36	3,740 kg	1,300 mm	50 kN
Ammann	ARX45	4,685 kg	1,380 mm	57.6 kN
Ammann	ASC110	11,495 kg	1,500 mm	206 kN
Ammann	ARS130	12,510 kg	2,130 mm	285 kN
Ammann	ARS150	14,580 kg	2,130 mm	325 kN
Ammann	ASC150	14,580 kg	2,130 mm	237 kN
Ammann	ARS220	22,060 kg	2,130 mm	375 kN

Rollers are available with smooth drum or sheepfoot



# Tractors

## Tractors 170 - 195hp

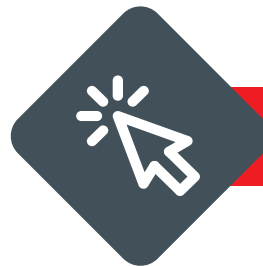

Find out more [here](#)

Manufacturer	Model	Machine Weight	Max Power	Dimensions
John Deere	6155M	7,800 kg	171 hp 125 kW	(W) 2,490mm x (H) 3,030mm
John Deere	6155R	8,120 kg	171 hp 125 kW	(W) 2,490mm x (H) 3,030mm
John Deere	6175R	8,300 kg	193 hp 142 kW	(W) 5,050mm x (H) 3,160mm



# Gators

## Gators 1t

Manufacturer	Model	Machine Weight	Dimensions
John Deere	XUV865M	1,056 kg	W 1.76 H 1.99, L 3.36



View our website [here](#)



# Digital



Plantforce Digital is a specialist division, focused on offering GPS solutions that allow our customers to increase the accuracy and efficiencies of their projects.

Our team of GPS experts are on the forefront of the latest innovations in this technology, ensuring we have an extensive fleet of GPS enabled machines and stand-alone units available for immediate hire. By only working with leading manufacturers, we are able to offer a consistent quality solution for all customers.

## What we do



Complete Machine



Set up support & design management solutions

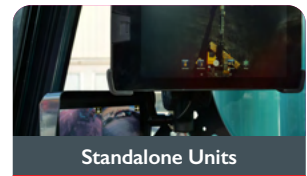

Standalone Units



# Why Choose Plantforce Digital

Plantforce Digital are the leading independent supplier of GPS machine control systems in the UK.



## Over 2 Decades of Experience (digital)

We have partnered with the leading manufacturers of GPS technology to grow the largest fleet of GPS machine control hire fleets in the UK.



## Huge Range Of Solutions For Your Needs

From just the GPS equipment to attach to your own machine or a GPS-ready machine for you to attach your kit to, through to a complete machine and GPS machine control set-up, Plantforce Digital offer the right solution for your project.



## Technical Support Team On Hand

We are always here to help you through your digital hire journey, we provide intelligent solutions for companies of all sizes. From installation, design consultation and ongoing technical support, you can start digital digging with the reassurance that our dedicated service team are available to support you, no matter where you are in the UK.

## Working with World Leaders



Not sure what you're looking for?

Speak to our Digital lead

T: 07470 527 111

# Cab Kits



## Leica Cab Kits

The iCG80 GNSS receiver in combination with CGA 60 GNSS antenna increases the performance of your iCON machine control solution, allowing you to work more productively than ever before. Increase dozer, excavator, drilling, excavator, wheel loader, grader and paver machine uptime.



### What products do these work with?

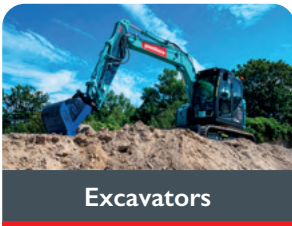

Excavators

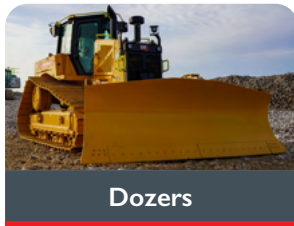

Dozers

#### Unique Machine Features:

- Easily transported by trailer.
- Ideal machine when working in confined spaces or with limited access.
- Easy to operate.
- Safe, compliant and competitive.

## Trimble Cab Kits

Our Trimble GPS machine control cab kit hire range will give you the ability to run GPS on your GPS-ready excavator without the financial commitment of purchasing the expensive equipment yourself.

Trimble is widely recognised as one of the leading manufacturers of GPS machine control technology. The new Trimble Earthworks Platform is designed to help operators do more in less time than ever before.



### What products do these work with?



Excavators

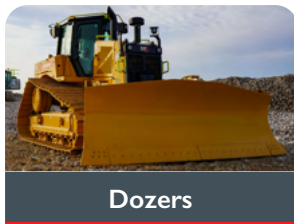

Dozers

#### Unique Machine Features:

- Suitable for all GPS-ready excavators and dozers
- Installation support available
- Technical user support is available
- Site set-up support is available
- Design preparation service is available
- Technology training is available
- Nationwide delivery and/or collection available

# Base Stations



## Leica Base Station

Our Leica GPS base station kit hire range will allow you to complete your own GNSS surveys without the financial commitment of purchasing the expensive equipment yourself.

Leica is widely recognised as one of the leading manufacturers of GPS machine control technology.



### Unique Machine Features:

- Compatible to work with all Leica GPS solutions
- Installation support available
- Technical user support is available
- Site set-up support is available
- Design preparation service is available
- Technology training is available
- Nationwide delivery and/or collection available



## Trimble Total Station

Our Trimble GPS total station kit hire range will allow you to complete your own GNSS surveys without the financial commitment of purchasing the expensive equipment yourself.

Trimble is widely recognised as one of the leading manufacturers of GPS machine control technology. The new Trimble Earthworks Platform is designed to help operators do more in less time than ever before.



### Unique Machine Features:

- Compatible to work with all Trimble GPS solutions
- Installation support available
- Technical user support is available
- Site set-up support is available
- Design preparation service is available
- Technology training is available
- Nationwide delivery and/or collection available

# Crushing & Screening

Find out more [here](#)



## What we do



Screening

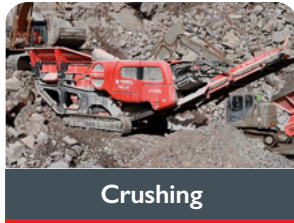

Crushing

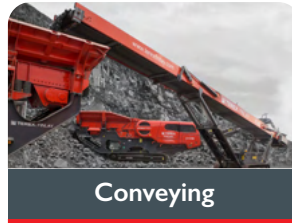

Conveying



Nationwide Support

Plantforce Crushing and Screening offers a range of crushing, screening and conveying solutions to help to increase production during peak periods.

With a fleet of the latest crushers, screeners, and conveyors, we offer an industry leading product range designed for maximum efficiency and performance.

We believe in listening to our customers and, when required, visiting your site to ensure we offer the right machine for your job. By taking this approach our aim is to become a trusted supplier of your business that you can rely on to provide a solution that works in a timely manner with an efficient and personable service. With our team of nearly 50 fully trained and equipped field service engineers, we offer reassurance that wherever you are in Great Britain, we are on hand to keep your operation running.

# Screeners

## Range Overview

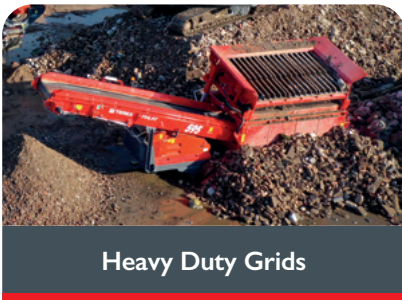

Heavy Duty Grids

Our heavy duty mobile grids are versatile and compact machines that can be used for primary screening and recycling applications on restricted work sites where space is at a premium.

Designed and constructed to the highest specification, they can withstand the toughest of applications from waste reclamation projects to quarry face and demolition environments, with features including heavy duty twin deck vibrating grids, wander lead operated and tracked undercarriages.



Scalping Screeners

Our range of tracked inclined screens are versatile, high capacity, robust and durable machines that can be operated in a wide range of primary and secondary screening applications.

The 6 Series range incorporates three-way and four-way split screeners that are equally suitable for processing and sizing aggregates, minerals and recycling applications.



Inclined Screeners

We offer arguably the largest range of mobile screening equipment for hire from leading global manufacturers.

Large or small, inclined, horizontal, 2 or 3 decks or 2, 3 or 4 way splits, we can offer screens to suit many industries and applications.

## Heavy Duty Grid 595

### Dimensions

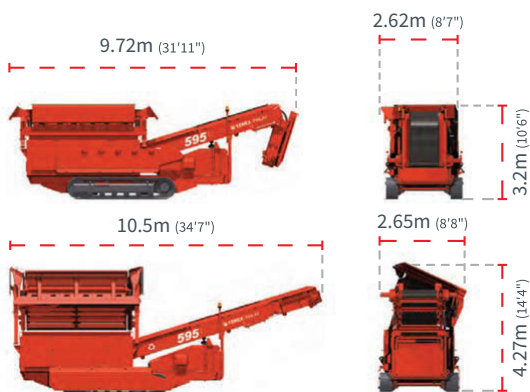

Grid Size	4500 x 2755 mm
Operating Weight	19,080 kg
Engine	Caterpillar C3.4 73.8Hp

### Unique Machine Features:

- Heavy duty aggressive scalping and screening double deck grid.
- Robust T-Bar cassette top deck and meshed bottom deck configuration for accurate screening of product material.
- Hydraulic folding main conveyor and grid raise allow for rapid set-up and tear down times.



## Scalping Screener 873+

### Transport & Working

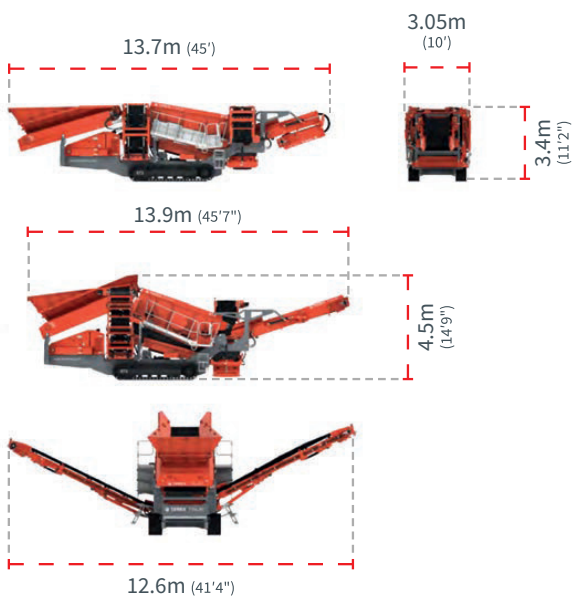

No. Stockpillers

3

Operating Weight

26,300 kg

### Unique Machine Features:

- Screen box angle can be hydraulically adjusted to an angle between 13° to 19°.
- Screen box discharge end raises hydraulically 500mm to facilitate mesh changing.
- Screen box can accept punch plate, cascade fingers, bofar bars and speedharps.
- Oversize conveyor angle can be adjusted from 18° to 24°.
- 1.2m wide Belt feeder complete with 7m<sup>3</sup> manual folding hopper.



## Scalping Screener 883+

### Transport & Working

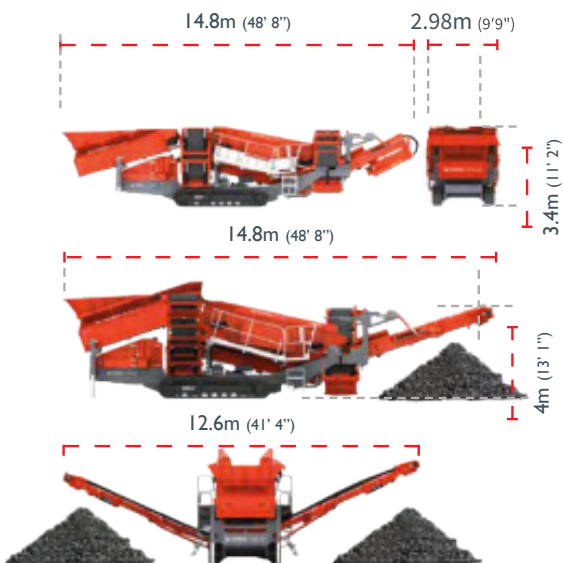

No. Stockpillers	3
Operating Weight	31,000kg
Ave. Fuel Consumption	11.34 L/hr
Ave. Throughput	700 mtph

### Unique Machine Features:

- Nearly blockage-free screening in the upper and lower deck.
- Flexibility to work in difficult waste processing, slag, biomass, compost, etc.



## Inclined Screener 674

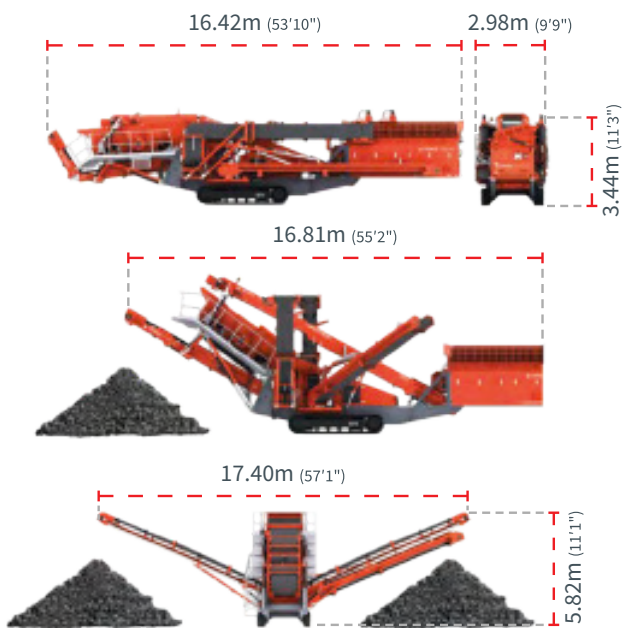

No. Stockpillers	3
Operating Weight	33,500kg
Ave. Fuel Consumption	12.9 l/hr
Ave. Throughput	300 mtph

### Unique Machine Features:

- L' style folding side conveyors which have allowed for the simplified folding of the 4th product conveyor.
- No transfer conveyor for oversized material from top deck, fed onto conveyor via a lined chute.
- Also included are fixed catwalks again to keep site set-up and tear down times to a minimum.
- Quick and easy to set-up.



## Inclined Screener 683

### Transport & Working

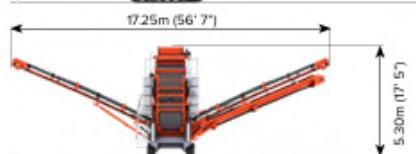

Screen Size	3.66m x 1.53m
Operating Weight	24,250 kg
Engine Type	CAT C4.4

#### Unique Machine Features:

- Galvanised all round fixed catwalk access
- Maximum utilisation of the two decks provides ultra-efficient screening capabilities even at small aggregate sizes
- Updated hopper and belt feeder gives improved material flow onto main conveyor
- Screen box angle can be hydraulically adjusted to an angle between 18° – 37°.

# Crushers

## Range Overview



Jaw Crushers

Our tracked mobile jaw crushers are renowned for their capabilities in the reduction and sizing of aggregates for construction materials and also recycling construction waste.

Our range of jaw crushers are designed to meet the toughest demands of primary crushing applications with their impressive power, reliability and proven performance.



Impact Crushers

The tracked mobile impact crushers we have available are renowned for their versatility and capabilities in the reduction and sizing of soft to medium natural granite and limestone and non-abrasive materials as well as recycling construction demolition waste.

Our range of impact crushers are ideal for producing a quality end product where grain shape, distribution and consistency is paramount.



## Jaw Crusher J-960

Jaw Size	900 x 600 mm
Operating Weight	29,250kg
Ave. Fuel Consumption	12.36 l/hr
Ave. Throughput	135 mtph

### Unique Machine Features:

- Quick and easy to set up.
- Improved clearances and easier service and maintenance access.
- Direct drive for fuel efficiency.
- Easy to transport.



## Jaw Crusher J-1160

### Transport & Working

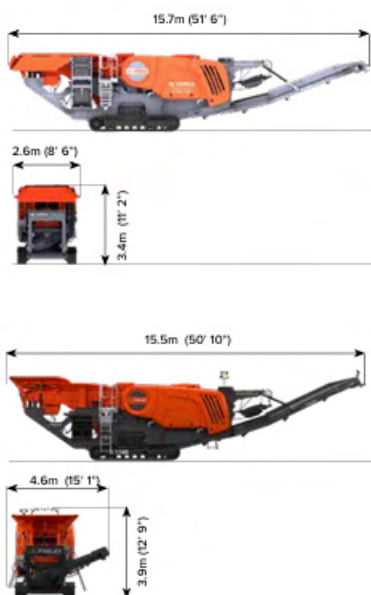

Jaw Size	1000 x 600 mm
Operating Weight	35,350 kg
Power Output	275 hp

### Unique Machine Features:

- Hydrostatically driven single-toggle jaw chamber
- Reverse functionality for clearing blockages quickly and safely
- Integrated pre-screen system reduces fines
- Automatic variable-speed VGF for continuous choke feeding
- Fully hydraulic CSS adjustment for fast jaw setting changes



## Impact Crusher 230R



Rotor Size	ø860 x 830 mm
Operating Weight	29,100 kg
Output Potential	250 tph

### Unique Machine Features:

- Compact Design: The Cobra 230R is built with a compact design, making it easy to transport and manoeuvre in tight spaces.
- Versatile Crushing.
- The Cobra 230R features an independent pre-screen that removes the fines before they reach the crushing chamber.
- The machine can be equipped with an optional recirculation system, allowing the operator to produce a high-quality finished product with a single pass.

# Conveyors



## Range Overview

### Tracked Conveyors

Our tracked mobile conveyor range allows you to move high volumes of material quickly and efficiently. Whether transferring material from one part of a process to another or simply stacking material in larger stockpiles, you will avoid the need for additional machines and operators.

Transport costs of each conveyor are kept to a minimum, due to the compact transport design. A simple yet robust design

allows for easy setup and positioning to fit the customers' requirements.

### Conveyor TC-65

#### Transport & Working

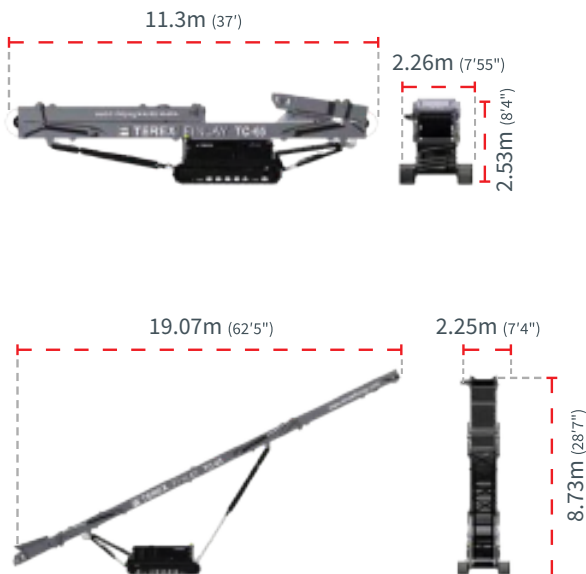

Conveyor Length	65'7"
Belt Width	42"
Operating Weight	11,300 kg
Ave. Fuel Consumption	6.2 l/hr
Ave. Throughput	400 mtph

#### Unique Machine Features:

- For accepting constant flow loads.
- Wide 1050mm/42" belt.
- Max discharge heights 10m/32'10".
- Stockpile capacity 1844m<sup>3</sup>/2412yd<sup>3</sup>.

# Compact

[View our compact page here](#)



Plantforce Compact is a dedicated division of light equipment. Just ask our experts where you will find everything for your needs.

May 2019 saw the opening of a highly anticipated brand-new division of the business, Plantforce Compact Range, with a new state-of-the-art depot based in Bristol backed by a massive £2.8 million investment into new highly specked compact machinery ranging from 0.8 ton to 3t cabbled excavators, telehandlers, trench compactors, hi tip dumpers and an industry specific range.

## 12 Man Welfare Unit



Mild steel or upgrade to stainless steel with 25 year anti-corrosion warranty	2 or 4 ram system deploys in under a minute	RedBox standard or patented Infinity with 2000 hour service intervals	Anti-vandal tow hitch cover – Flap or cowl (model dependent) with bear claw locking system	Road Light Surface mounted 12V LEDs	Ball coupling or pin & eye
---	---	---	--	-------------------------------------	----------------------------

## Dust Suppression Unit

BBW35KPE+ES

The Brendon BBW35KPE, BBW35KPE+ES & BBW30KLN+ES Bowser washers are designed and built for the toughest of cleaning in remote and difficult to access locations and used in many industrial applications.

With a tank capacity of 940 litres giving an approximate cleaning time of 1 ½ hours on a full tank, our Pressure Washer Trailer will complete most of your cleaning requirements.



Weight	Water Tank	Max Pressure Bar - (Psi)
500 kg	940 litre water tank	240 BAR / 3500 PSI

Model	Model	Weight (Empty)	Capacity
Electric Pump	10TCG	540 kg	949 Litres
Hand Pump	10TCG	540 kg	949 Litres
Electric Pump	20TCG	823 kg	2,091 Litres
Hand Pump	20TCG	823 kg	2,091 Litres

## Fuel Cube

Transcube 2000L Static

The Transcube 2000L Static fuel cube is a large, stationary fuel storage tank designed for safe and efficient fuel storage on job sites, remote locations, and other industrial settings.

With a capacity of 2000 litres, it provides a significant amount of fuel storage without the need for multiple smaller tanks.



# Hydraulic Attachments

Now with over 360 items in the fleet, Plantforce stands as one of the largest attachment hire fleets in the country.

Plantforce Attachments offer hydraulic breakers, grabs, grapples, shears, munchers, crusher buckets, riddle buckets, ripper teeth, pallet forks and much more.

With over 25 years of expertise in the plant hire industry Plantforce is a company that is well known and appreciated for its wide and safe range of specialist industry attachments.



## What we do



Breakers



Selector Grabs



Compactor Plates



Augers



Pallet Forks

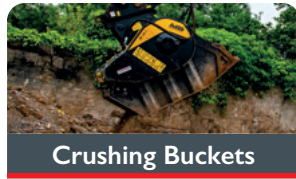

Crushing Buckets

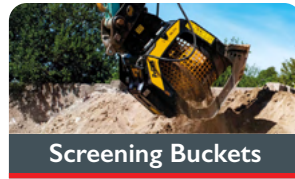

Screening Buckets



Rock Wheels



Pulverisers



Multi Processors - Shears

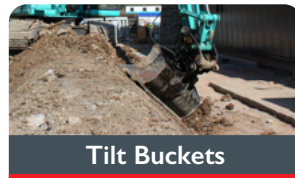

Tilt Buckets

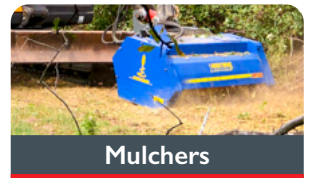

Mulchers



Tin Bin



Piling Hammers



View all attachments [here](#)



Model	Operating Weight	Overall Length	Working Pressure	Suitable Excavator
B06	68 kg	932 mm	6~12 MPa	0.8~1.2 ton
B30	190 kg	1,352 mm	8~12 MPa	1.2~4 ton
B50	333 kg	1,603 mm	10~14 MPa	3~8 ton
B70	431 kg	1,805 mm	10~14 MPa	5~8 ton
B140	929 kg	2,225 mm	12~16 MPa	10~15 ton
B210	1,738 kg	2,764 mm	13~17 MPa	18~25 ton
B360	2,937 kg	3,200 mm	14~18 MPa	28~36 ton
B450	3,713 kg	3,595 mm	14~18 MPa	40~50 ton
B650	4,380 kg	3,766 mm	14~18 MPa	42~81 ton

## Breakers 0.8t - 50t



**Our Daemo breakers all come with an anti-blank firing system**

- Products are ranging in size from 0.8t to 50t. Auto grease systems are available on selected breakers which allows you to work without having to stop and grease it several times a day, also from 7t and above they come with a 2 stroke selection system which can drop fuel consumption and improve performance.

Model	Operating Weight	Overall Length	Working Pressure	Suitable Excavator
PH-06	94 kg	991 mm	20 ~ MPa	1~2 ton
PH-07	112 kg	1,035 mm	21 ~ MPa	1.5~3 ton
PH-1	162 kg	1,154 mm	21 ~ MPa	2~3.5 ton
PH-2	200 kg	1,240 mm	21 ~ MPa	3~5.5 ton
PH-3	314 kg	1,395 mm	21 ~ MPa	4~9 ton
PH-4	465 kg	1,570 mm	21 ~ MPa	6~12 ton
GH-6	851 kg	1,931 mm	21 ~ MPa	12~18 ton
GH-9	1,482 kg	2,356 mm	21 ~ MPa	17~24 ton
GH-15	2,618 kg	2,933 mm	21 ~ MPa	28~45 ton
GH-18	3,067 kg	3,056 mm	21 ~ MPa	38~50 ton

## Breakers 1t - 80t



**A better design that combines efficiency, reliability and serviceability**

- Standard on all medium and large NPK hydraulic hammers, our shock-absorbing mounting bracket uses special heavy-duty rubber mounts to absorb shock, recoil and impulse vibration.
- The unique one-piece design eliminates the need for mechanical springs and overly heavy mounting brackets. The net result is minimization of machine wear and improved operator comfort for greater reliability and productivity.

# Selector Grabs



## Selector Grabs 5t - 40t

**NPK®**

Selector grabs are commonly used in construction and industrial sites for various purposes.

These versatile machines come with a wide range of attachments that allow them to tackle different tasks efficiently.

Model	Operating Weight	Capacity	Jaw Opening	Suitable Excavator
DG-9	450 kg	180 L	1,632 mm	5~9 ton
DG-16	875 kg	425 L	1,850 mm	10~16 ton
DG-20	1,230 kg	500 L	2,050 mm	14~20 ton
DG-30	1,850 kg	800 L	2,410 mm	18~30 ton
DG-40	2,050 kg	900 L	2,410 mm	25~40 ton

Model	Operating Weight	Capacity	Jaw Opening	Suitable Excavator
DI5H-T	1,100-1,500 kg	3,000 KG	740 mm	11~15 ton

**KINSHOFER**

**DG-40**

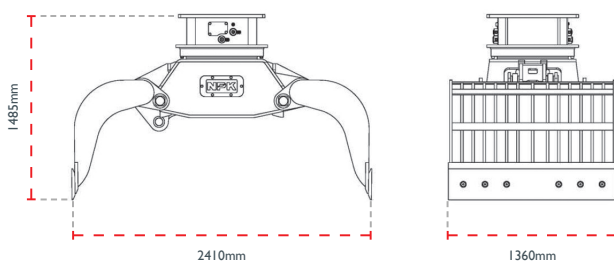

**DI5H-T**

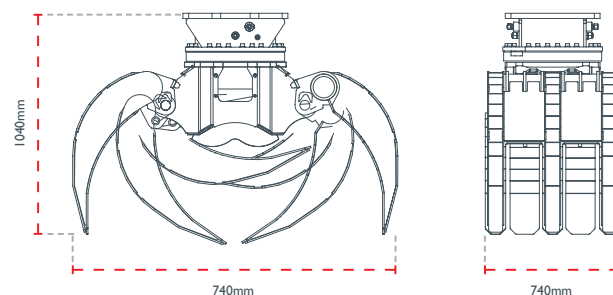

# Compactor Plates



## Compactor Plates 2.5t - 63t

The NPK range of compactor plates are designed and built to meet today's demands for greater on-site productivity, expanding and enhancing the versatility of your excavator

**NPK®**

- NPK's versatile Construction Compactor can work productively virtually anywhere your excavator can reach. In trenches, over and around pipe, to the top of piling and sheeting. Next to foundations and around obstructions. Even on steep slopes or rough terrain where conventional rollers and other machines either can't work or would be hazardous to try.

Model	Operating Weight	Impulse Force	Length X Width	Suitable Excavator
C-2D	172 kg	1,600 kg	635 x 320 mm	2.5~5.5 ton
C-4C	436 kg	3,600 kg	860 x 580 mm	4.5~11.5 ton
C-6C	778 kg	7,300 kg	1,020 x 740 mm	7~20 ton
C-8C	1,056 kg	11,000 kg	1,170 x 860 mm	14~34 ton
C-12C	2,030 kg	20,400 kg	1,470 x 1,140 mm	35~63.5 ton

**C-12C**

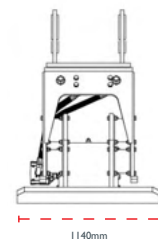

# Mulcher



## Mulcher 3.5t - 15t



Suitable for excavators and skid steer loaders, the Variable Mulcher provides a working width of up to 1.5m.

Both the VM1000 & VM1500 have the unique feature of being able to change the drum on-site, adapting quickly between parent machines for maximum versatility & flexibility on the

job, without having to return to the yard. The ability to attach a skid steer frame and excavator hitch at the same time, along with a removable pressure gauge & push bar allows for easy adaptation between parent machines when out on site. The fixed tungsten teeth drum gives a robust blunt cutting edge for grinding through thick timber, hedges and branches. The swinging hammer teeth drum gives a cleaner, more precise cut for dense bushes, smaller trees & even slashing grass.

Model	Operating Weight	Overall Length	Working Pressure	Suitable Excavator
TC2-80	242 kg	800 mm	250 bar	3.5~6.5t
VM1000	400 kg	1,000 mm	160-180 bar	5-10t
VM1500	800 kg	1,500 mm	220-240 bar	10-15t

# Screening Buckets



## Screening Buckets | 4t - 20t

Model	Operating Weight	Load Capacity	Dimensions	Excavator
MB-S14 S4	1.1 t	1.10 m <sup>3</sup>	1,195 x 1,440 mm	14~20 ton

MB - S14

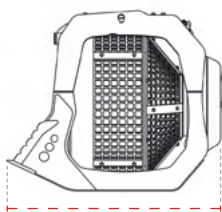

1195mm

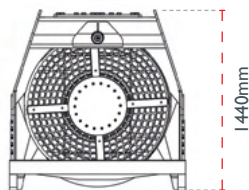

1440mm

### Perfect for on-site cleaning and screening of inert materials

- The MB screening bucket is a piece of equipment that works by taking advantage of the hydraulic system of the excavators to which it is fitted.
- It has many areas of applications: from building demolitions in general, to the requalification of former industrial and urban areas to the processing of excavation materials, from the earth movement sector to road works, from quarries to mines, from environmental reclamation to applications on rocky soil.

# Piling Hammers



## Piling Hammers 7t - 55t

Model	Max Hydraulic Flow	Total Mass	Clamp Force	Suitable Excavator
EMV220	250 L/min	580 kg	26.5 t	7~22 ton
EMV300	250 L/min	965 kg	36 t	12~35 ton
EMV550	400 L/min	1,500 kg	66 t	30~55 ton

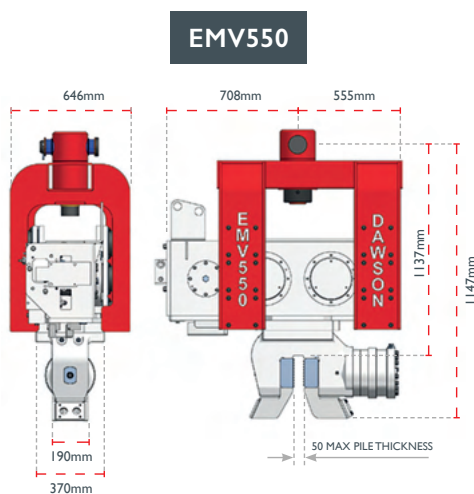

Dawson excavator mounted vibrators have been designed specifically to work in place of an excavator bucket to drive and extract piles

- The pile can be lifted to vertical using the built-in lifting chain where it is then gripped tightly in a powerful hydraulic jaw. Once secured, the pile is then vibrated with high frequency vibrations so as to 'fluidise' the soil resisting the pile.
- Down-crowd force applied by the excavator boom, coupled with the self-weight of the pile and the vibrator, provides sufficient force to push the pile into the ground. Naturally, the process works in reverse for pile extraction. The equipment offers a highly productive and cost effective piling rig based around a standard, readily available excavator.

# Tilt Buckets



## Tilt Buckets 5t - 22t

The Strickland heavy duty hydraulic tilt buckets have been designed and manufactured in the UK and are all CE marked to ensure they will perform in the very toughest of operating environments

- This heavy duty hydraulic tilt bucket operates with one hydraulic piston. Our hydraulic tilt buckets are hugely popular, available for all makes and models of excavators.

10 - 14t

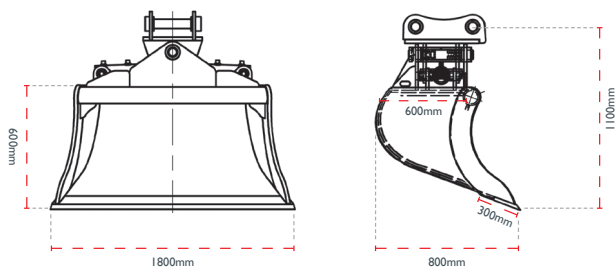

Model	Bucket Width	Suitable Excavator
5-8t	1,520 mm	5~8 ton
10-14t	1,800 mm	10~14 ton
20-22t	1,850 mm	20~22 ton

# Crushing Buckets



## Crushing Buckets | 14t - 30t

Perfect for on-site crushing of inert materials, the MB Crusher Bucket takes advantage of the hydraulic system of the excavators. The range is suitable for 14 - 30 ton machines.

It has many areas of applications: from building demolitions in general, to the reclamation of former industrial and urban areas to the processing of excavation materials, from the earth movement sector to road works, from quarries to mines, from environmental reclamation to applications on rocky soil.

Model	Operating Weight	Load Capacity	Working Pressure	Excavator
BF60	1.8 ton	0.55 m <sup>3</sup>	215 bar	14 ton
BF90	3.6 ton	0.90 m <sup>3</sup>	220 bar	20~30 ton

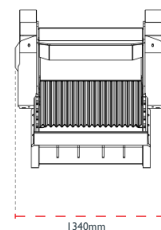
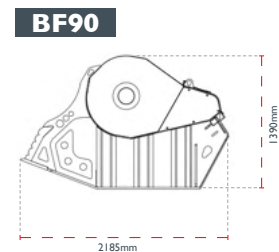

# Rock Wheels



## Rock Wheels 6t - 30t



When your application requires small fixed-section trenching i.e. for the laying of utilities up to a maximum depth of 800mm and width of 30-250mm asphalt, concrete and rock Simex T wheel excavators are your solution

- With high level of visibility, wheel protection at all depths and hydraulic piston motors with direct wheel drive provide you with safety and high performance for the works requiring cutting small sections of trenches on hard or compacted surfaces.

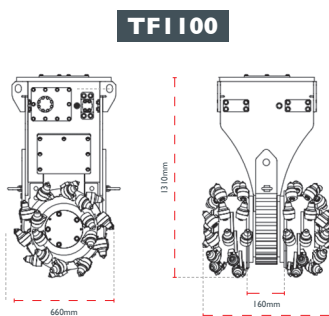

Model	Operating Weight	Drum Width	Working Pressure	Excavator
TF400	476 kg	635 mm	5,100 psi	6~12 ton
TF600	635 kg	711 mm	5,100 psi	9~16 ton
TF850	1,134 kg	812 mm	5,100 psi	14~20 ton
TFI 100	1,451 kg	864 mm	5,100 psi	20~34 ton



## Tin Bin TC2

The tinbin TC2 allows you to excavate quickly, cleanly and precisely. Dry suction excavation means you can dump on site and avoid slurry disposal charges. Air is non-conductive and allows you to stay on site longer, boosting productivity!

Model	Operating Weight	Overall Length	To Suit Max Fork Size	Suitable Excavator
TC2	1,300 kg	1,800 mm	280 bar	20t-30t



## Pulverisers

### Pulverisers 10t - 38t

Pulverisers crush and process concrete on site separating it from re-bar and leaving behind smaller chunks, making the material easier for processing and manoeuvring



- We have fixed jaw or rotational pulverisers available for hire.

Model	Operating Weight	Max Jaw Opening	Working Pressure	Excavator
G120	1,160 kg	775 mm	28 MPa	10~17 ton
G18	2,054 kg	823 mm	26 MPa	17~22 ton
G28	2,960 kg	1,000 mm	28 MPa	25~38 ton



Model	Operating Weight	Max Jaw Opening	Working Pressure	Excavator
DMPI40	1,350 kg	867 mm	31 MPa	14~22 ton

# Multi Processors



## Multi Processors 20t - 50t

# NPK®

Our NPK multi processors have different jaws to suit different applications

- The NPK multi processor has a pulveriser jaw for cutting through re-enforced concrete, a blade for cutting re-bar and a 360-degree rotation.
- NPK source and build to the highest quality to ensure high productivity and minimal down time.

Model	Operating Weight	Max Jaw Opening	Working Pressure	Excavator
M20	Pulveriser 2,100 kg	Pulveriser 770 mm	25 MPa	17~24 ton
	Shear 2,100 kg	Shear 540 mm		
	Cracker 2,000 kg	Cracker 940 mm		
M28	Pulveriser 3,150 kg	Pulveriser 910 mm	25 MPa	28~40 ton
	Shear 3,130 kg	Shear 638 mm		
M38	Pulveriser 4,150 kg	Pulveriser 1140 mm	25 MPa	35~45 ton
	Shear 4,250 kg	Shear 735 mm		

## DAEMO

Features Quick Change Jaws, replace within 30 minutes!

Model	Operating Weight	Max Jaw Opening	Working Pressure	Excavator
DMP200Q	Pulveriser 2,200 kg	Pulveriser 843 mm	31 MPa	20~30 ton
	Shear 2,037 kg	Shear 393 mm		

# Augers



## Augers 1.5t - 20t



Model	Operating Weight	Torque Range	Speed Range	Excavator
X2500	48 kg	830 - 2,847 Nm	36 - 87 rpm	1.5~3 ton
8000 MAX	116 kg	2,717 - 8,152 Nm	33 - 70 rpm	6~8 ton
15000 MAX	173 kg	5,024 - 15,071 Nm	20 - 43 rpm	10~15 ton
20000 MAX	268 kg	13,043 - 19,564 Nm	16 - 33 rpm	13~20 ton

This range of augers have been specifically designed for use on excavators between 1.5t - 20t and large backhoes

- They are available with a number of wearpart combinations, catering from soft grounds all the way to mixed rocky grounds and even permafrost.
- All Auger Torque augers are built from high grade steel and incorporate many features that will allow you to work more efficiently and will make your job easier. Shallow pitch flights ensure they will cut with maximum efficiency and, most importantly keep the spoil on the flights when removed from the hole.

8000 MAX



Earth Drill Hitches

ALSO AVAILABLE



Augers and Extensions

# Non - Hydraulic Attachments



## What we do

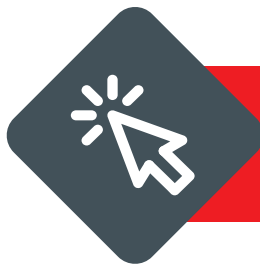
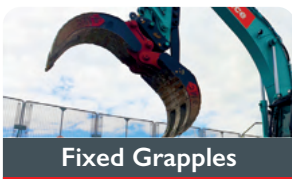
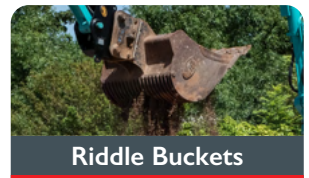
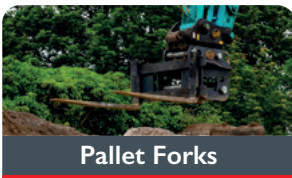

Not sure what you're looking for?  
Speak to our Attachments lead  
T: 07464 928 661

View all attachments [here](#)

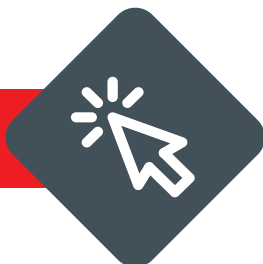

# Pallet Forks



## Pallet Forks 5t - 23t

Model	Operating Weight	Depth	Width	Suitable Fork Lift
5-8t	253 kg	1,195 mm	1,000 mm	5~8 ton
13-23t	362 kg	1,195 mm	1,000 mm	13~23 ton

The Strickland range of fork attachments are designed and manufactured in the UK to CE specifications

- All our pallet forks come with adjustable pins for use with various hitches, we also offer a wide range of fork extensions, please get in contact for more information.

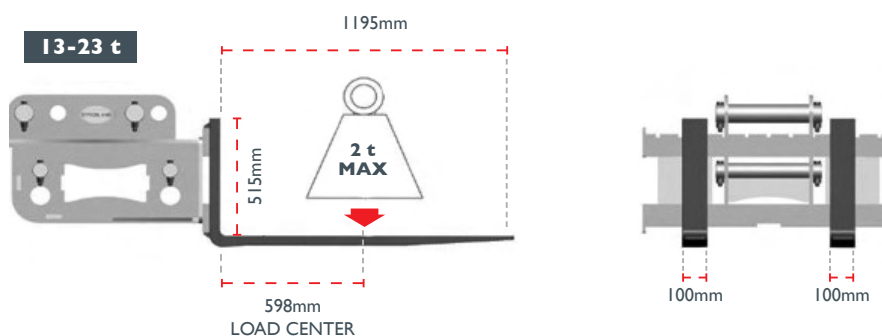

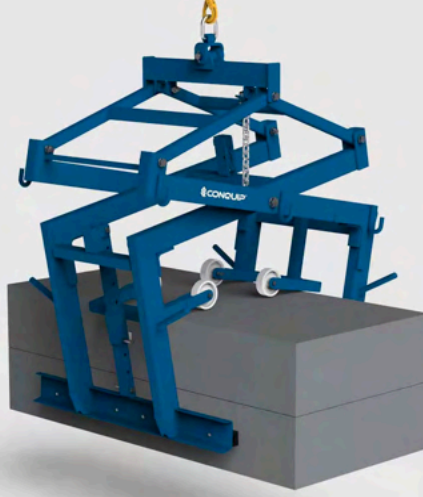

# Block Grabs

## Block Grabs 5t - 8t



The Conquip Block Grab is a mechanical grab for materials lifting blocks and bricks, commonly with an excavator but sometimes with a crane. It is also suitable for handling all types of concrete products, such as concrete slabs, kerb stones and paving blocks.

Top arms and load levelling arms increase durability, and safety while the automatic catch mechanism enables a single operator to stack or unstack loads.

Model	Operating Weight	Overall Length	Working Load Limit	Suitable Excavator
CA 105-01000	250 kg	1,560 mm	1,800 kg	5~8 ton



# Kerb Lifters

## Kerb Lifters 8t+

The Kerb Lifter, or mechanical kerb grab, is designed for the safe handling of kerbs, steps and other pre-formed sections. It can

be machine lifted by crane or other suitable lifting apparatus, by a central lifting point, or manually lifted using the handles.

Model	Operating Weight	Overall Length	Working Load Limit	Suitable Excavator
MH701AA	34 kg	675 mm	600 kg	8t +

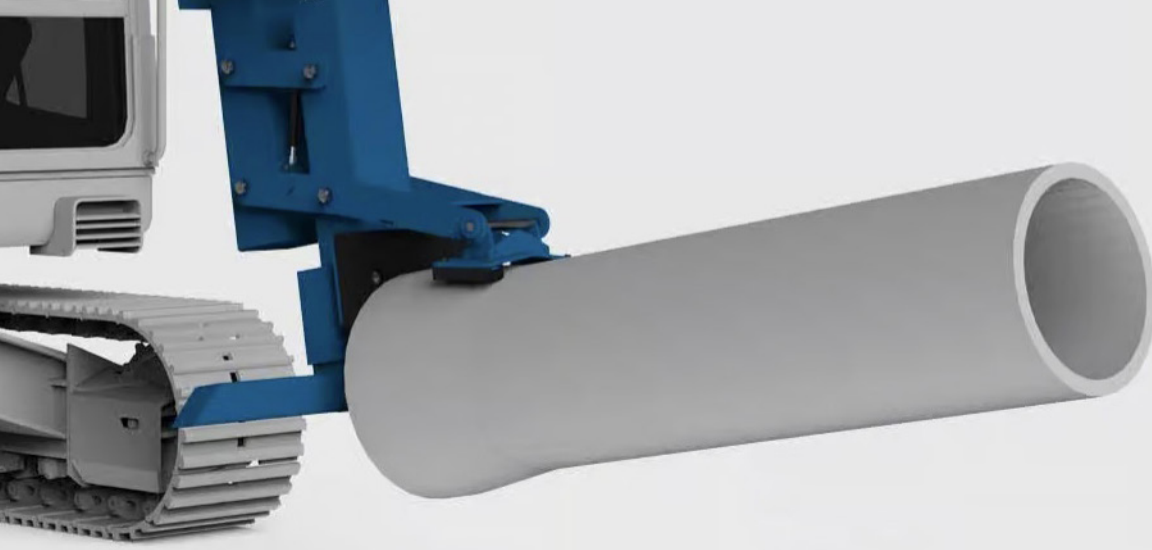

# Pipe Lifters

## Pipe Lifters 13t - 22t



The Conquip Excavator Mechanical Pipe Lifter is an excavator attachment with mechanically operated grip and release mechanism used for unloading pipe sections from delivery vehicles, transporting them around site and placement in

trenches. A safe alternative to other pipe lifting methods, it avoids the need for ground workers to be in the trench during pipe installation and replaces traditional slinging methods for unloading trucks.

Model	Operating Weight	Overall Length	Working Load Limit	Suitable Excavator
EA012 - 04000	290 kg	2,910 mm	4,000 kg	13t - 22t

# Compaction Wheels

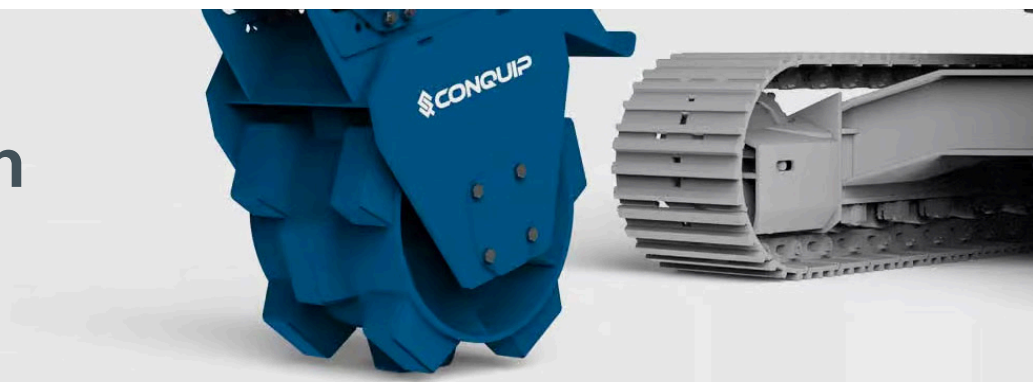

## Compaction Wheels 13t - 22t



Model	Operating Weight	Overall Length	Compaction Width	Suitable Excavator
EA023	510 kg	1,010 mm	1,800 kg	13t -22t

# Fork Extensions

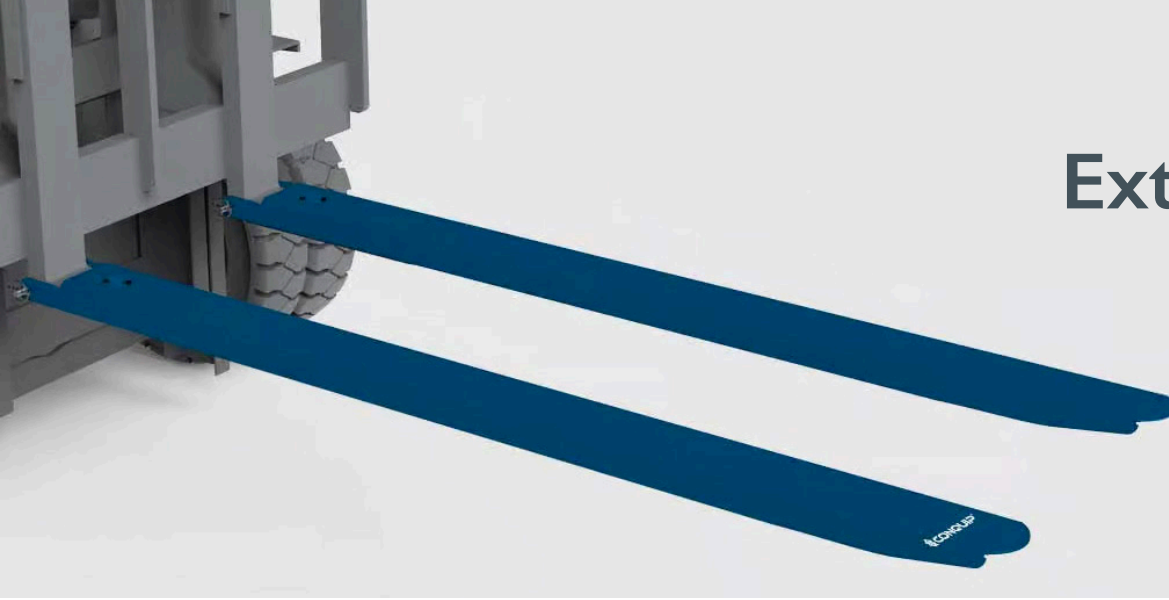

## Fork Extensions



Fork Extensions extend the forks of a forklift or telehandler to increase its capacity and provide a simple, effective solution for stabilising long and awkward loads.

This attachment is easy to fit and increases the versatility of your forklift or telehandler, saving on hiring other machinery to move abnormal loads.

Operating Weight	Overall Length	To Suit Max Fork Size
68 kg	1,800 mm	100 x 50 mm

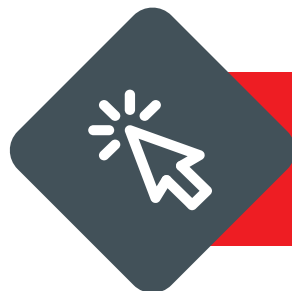

**Not sure what you're looking for?**  
Speak to our Attachments lead  
T: 07464 928 661

# Riddle Buckets



## Riddle Buckets 5t - 45t



Well suited to rocky soils, our riddle buckets are manufactured to work with machines from 5 tonne to 45 tonne, with various sizes from 24 to 72 inches

- We have numerous buckets in stock with different specs, please contact us for more information.

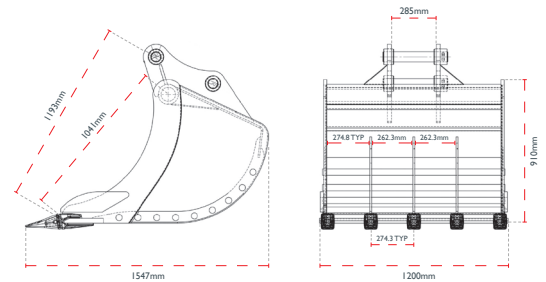

# Ripper Teeth

## Ripper Teeth 8t - 45t

Here at **Plantforce Attachments** we are always adding to our stock so please feel free to call us and see what's the latest we have available.

These are designed and manufactured to help reduce wear on both your machine and buckets

- The sloping and penetrative design 'rips' up hard soil and rock with ease, making digging easier. This helps reduce stress on buckets and machines, making the process more economical (as less stress on parts of the excavator and buckets inevitably means less down time).
- Rippers are available for all machines from 8 tonne to 45 tonne and can be manufactured with a variety of wear parts added to suit your application.

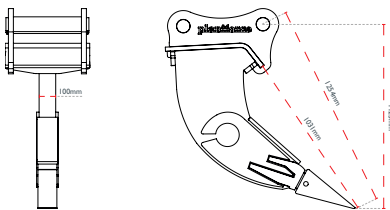

# Fixed Grapples



## Fixed Grapples 20t - 50t



Model	Operating Weight	Full Open	Suitable Excavator
HDG110	1,225 kg	2,413 mm	18~22 ton
HDG160	2,645 kg	3,607 mm	40~52 ton

HDG160

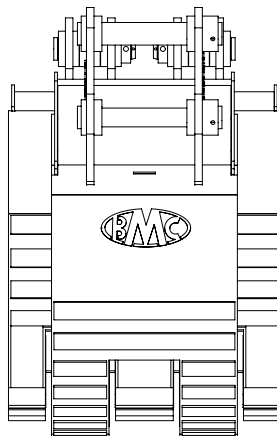
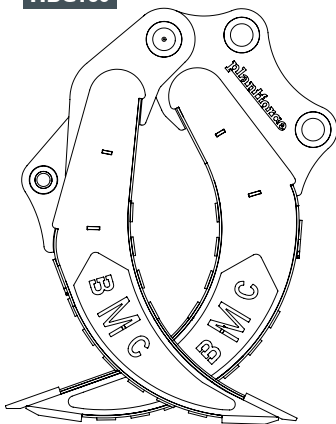

Made with abrasion resistant, high-tensile strength steel for durability, boxed tines for increased strength, maximizes production while minimizing downtime

- Replaceable bearings in main hinges with O-rings to protect the pins by keeping grease in and dirt out for a longer life span. Available with optional wear package, ideal for demolition, scrap handling, land clearing, and refuse handling.











## Let Us Move Your Machines.

The Plantforce Heavy Haulage division is dedicated to providing its customers with the highest level of service and safety when transporting plant or heavy equipment. The service can provide a one-stop shop for all your transportation needs, with a vast

range of vehicles on offer, from large trucks and trailers to small vans. The team of experienced, qualified and highly skilled drivers are committed to delivering the best experience when completing your heavy haulage project.



18t Beavertail



32t Beavertail



44t - 65t Tractor Unit



100t - 120t Tractor Unit

## Introducing A New Plant and Machinery Haulage Solution

With a fleet comprising of general plant vehicles ranging from 4 & 8 wheel rigid beavertails to 3 & 4 axle step frame trailers, we can cater for both standard Construction and Use Loads (C&U) and abnormal loads (STGO). As well as this all drivers carry a tablet which allows them to capture proof of delivery / collection with signatures and photos via the driver app.



### Euro 6 Compliant

All our trucks are fitted with the latest standards that all new engines must be compliant with.



### Tracking Systems

Fitted with tracking systems to provide live vehicle locations and traffic information.



### Volvo Connect

Fitted with Volvo Connect Telematics which enables us to track fuel consumption and data.

# Fully Compliant Transport Solutions



CLOCS Champion & FORS Silver Accreditation... but we are going for Gold!



NPORS Loader Securer / Plant Mover qualified drivers



TFL, FORS & HS2 Compliant Fleet



## Safety

Plantforce Heavy Haulage is FORS Silver accredited and CLOCS Champion, demonstrating our exemplary levels of best practice in safety, efficiency and environmental protection.

All fleet vehicles are equipped with the following:

- ✓ 360 Degree camera systems
- ✓ In Cab cameras
- ✓ Fall restraint systems
- ✓ Audible Warning System, Blind Spot Aids & Close Proximity Sensors

Our drivers and staff are highly experienced and hold NPORS Plant Loader / Securer (STGO) and Plant Mover qualifications.



Find out more [here](#)

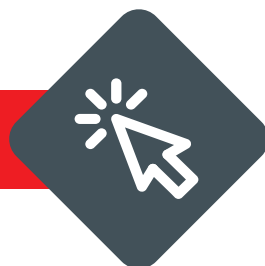

# Our Depots

plantforce

## HQ - Weston Depot

Winterstoke Road  
Weston Super Mare  
Bristol BS23 3YW  
01934 640 840

## Bristol Depot

Plantforce Compact  
South Liberty Lane, Bristol BS3 2UQ  
01934 640 840

## Cornwall Depot

Moordown, St Ives  
Liskeard PL14 3NA  
01579 383 185

## Devon Depot

Chancel Lane, Pinhoe  
Exeter EX4 8JT  
01392 344 880

## East of England Depot

Babraham Road, Fulbourn  
Cambridge CB21 5HR  
01934 640 840

## London Depot

Civic Way  
Ruislip HA4 0YS  
01934 640 840

## Midlands North Depot

Diamond Way  
Stone ST15 0SD  
07000 606 606

## Midlands South Depot

Snitterfield Road, Bearley  
Stratford-upon-Avon  
Warwickshire CV37 0EX  
0121 371 0900

## North West Depot

Park Lane Ind Estate, Wigan Road  
Ashton-in-Makerfield WN4 0BZ  
0121 371 0900

## Scotland Depot

Lauchope Road, Newhouse Ind Estate  
Motherwell ML1 5RX  
07000 606 606

