

MACHINES

# ASC & ARS SINGLE DRUM ROLLERS

ASC & ARS SERIES SOIL COMPACTORS



**AMMANN**

# YOUR BENEFITS AT A GLANCE

WHAT CHARACTERISES THE SINGLE DRUM ROLLERS  
FROM AMMANN?



## PRODUCTIVITY

### High compaction output

Faster compaction of thicker layers with less passes

### No rear axle concept

Compact machine design for high stability, manoeuvrability and access

### ACE<sup>pro</sup>/ACE<sup>force</sup>

Intelligent compaction tools for best effectivity

## ERGONOMICS

### Cab design

Spacious cab with low noise levels for Operator comfort

### Simple and reliable dashboard

Intuitive machine control even with unskilled Operator

### Visibility

Perfect all-around machine visibility for higher safety on the job-site

## SERVICEABILITY

### Tiltable cabin and engine hood

Perfect access to service points

### Ground access to service and maintenance points

Easy access to service points without additional tools

### Maintenance friendly design

Easy and fast daily maintenance



## ASC & ARS SOIL COMPACTORS

### SMOOTH DRUM



ASC 50



ASC 70



ASC 100



ASC 110



ASC 120



ASC 130



ASC 150



ASC 170



ARS 200



ARS 220



### PADFOOT DRUM



ASC 30



ASC 50



ASC 70



ASC 100



ASC 110



ASC 120



ASC 130



ASC 150



ASC 170



ARS 200



ARS 220



“ Built for traction  
and efficiency.”



# ELIMINATE PASSES

Compaction is about reaching your goals in the fewest passes possible. Ammann soil and asphalt compactors provide that needed efficiency through industry-leading technology and an ability to direct more force toward the target and away from the machine. The result: quality results in fewer passes and a more productive and profitable jobsite.

## INTRODUCTION

- The family of single drum rollers follows the Solid Power DNA and provides excellent operator comfort and unique compaction output and productivity.
- The line consists of machines ranging from 3 t to 26 t and utilising the latest Cummins, Kubota and Deutz Tier 4i/EU Stage 3B or Tier 3 /EU Stage 3A engines or Tier 4f/EU Stage 4.

# COMPACTION OUTPUT

## MEETING AND MEASURING GOALS

All Ammann rollers feature vibratory and amplitude systems that help you quickly reach compaction targets. Optional Intelligent Compaction systems can provide even more efficiencies.

### ASC 30

- Single-amplitude system
- PD drum as standard
- Smooth shell Kit optionally available

### ASC 50 HD-ARS 220 VIBRATORY SYSTEMS

- High compaction performance and quality
- Heavy-duty 2-stage vibrator
- Simple system for adjusting amplitude/frequency by selection of vibratory shaft rotation direction
- Multiple amplitudes and frequencies available with ACE<sup>PRO</sup>





# YOUR BENEFITS

## BOOST YOUR PERFORMANCE ON ANY JOBSITE

It's hard to know what the next job will bring: clay, sand or something in between? Ammann Soil Compactors provide industry-leading compaction outputs – whatever the application. Your jobsite conditions will change, but you will always have a need for productivity and performance.

### DESIGN

- Comfort built into cabs to improve operator productivity and reduce fatigue
- Optimal visibility to front, sides and rear
- Control switches located on the dashboard or in the armrest for convenience
- Multifunctional display in steering wheel for full utilisation of all machine functions on the ARS models
- Low sound levels for improved comfort

### HIGH COMPACTION OUTPUT

- Industry-leading compaction output
- Tried-and-tested Ammann vibratory system
- Varied vibratory and amplitude settings that drive the energy into the material and away from the operator
- Machine design to properly direct dynamic forces

### WIDE RANGE OF OPTIONS

- Available with several engine types to match your local requirements
- Additional options available that fit your specific needs

### COMPACTION TECHNOLOGY

- Available with proprietary Ammann Compaction Expert (ACE) systems ACE<sup>force</sup>, ACE<sup>pro</sup> and ACI<sup>eco</sup>, depending on models
- Identifies uncompacted spots
- Displays and evaluates all measured values including load-bearing capacity of material, number of passes and frequency/amplitude values

### INTELLIGENT COMPACTION OPTIONS

- ACE<sup>pro</sup>, which provides compaction measurement, automatic control and a documentation system
- ACE<sup>force</sup>, which provides compaction measurement, guiding function and a documentation system
- ADS (Ammann Documentation System), which records and evaluates all relevant compaction process data
- GPS mapping, which adds information to ACE documentation and offers a location view
- ACI<sup>eco</sup> (Ammann Compaction Indicator), which measures relative compaction value and compaction progresses with every pass

### AMMANN SOLUTION



### COMPETITORS SOLUTION



### NO REAR AXLE

- Compact machine design
- Has low centre of gravity for high stability
- Improves manoeuvrability
- Enhances visibility and safety
- Offers easy service access

# BUILT FOR VERSATILITY

## ROLLERS EXCEL IN VARIED APPLICATIONS

Ammann offers many models of rollers so their varied weights and sizes can help you succeed in everything from tight spaces to wide-open jobsites. Easily adjusted amplitude and frequency bring additional versatility once your crew is rolling.

### TOP LAYERS

Single Drum Rollers not used

### SUB-BASES

**ASC (30/ 50)**

**Gravel mixtures:**

recommended lift thickness  
max. 150 mm (5.91 in)

**Sub-base course:**

recommended lift thickness  
max. 250 mm (9.84 in)

**Sub-grade:**

not recommended

### SUB-BASES

**ASC (70)**

**Gravel mixtures:**

recommended lift thickness  
max. 250 mm (9.84 in)

**Sub-base course:**

recommended lift thickness  
max. 350 mm (13.8 in)

**Sub-grade:**

not recommended

### SUB-BASES

**ASC (100/110/120/130/150/170)**

**Gravel mixtures:**

recommended lift thickness  
max. 300 mm (11.8 in)

**Sub-base course:**

recommended lift thickness  
max. 500 mm (19.7 in)

**Sub-grade:**

recommended lift thickness  
max. 1000 mm (39,4 in)

### SUB-BASES

**ARS (200/220)**

**Gravel mixtures:**

recommended lift thickness  
max. 400 mm (15.75 in)

**Sub-base course:**

recommended lift thickness  
max. 600 mm (23.6 in)

**Sub-grade:**

recommended lift thickness  
max. 1700 mm (66,9 in)

### APPLICATIONS

#### LIGHT COMPACTOR

- Pipeline construction
- Social and industrial development areas
- Structure backfill work
- Confined work spaces
- Airport construction
- Electric cable construction
- Dumpsite construction
- Sub-base of roads

#### MEDIUM AND HEAVY COMPACTOR

- Motorways
- Railways
- Airfields
- Rock fill dams
- Industrial zones
- Harbours
- Residential areas

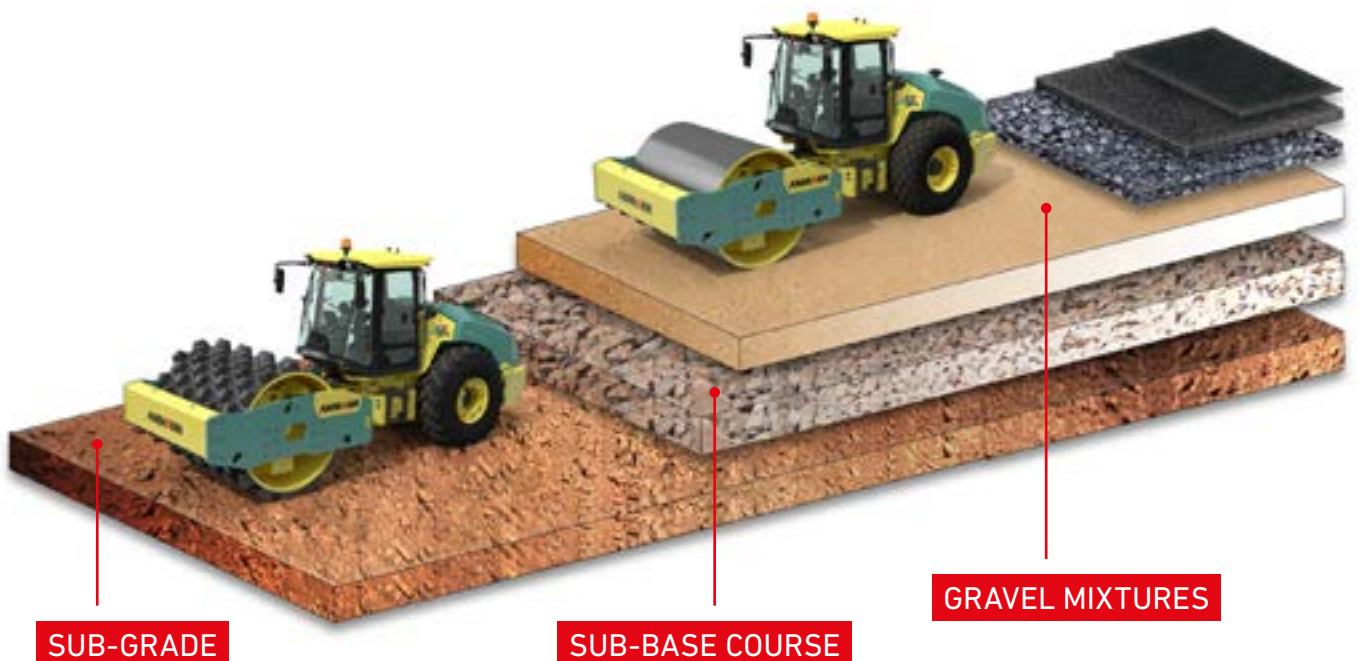



“Ammann Soil Compactors provide industry-leading compaction outputs regardless of the application.”





# OPERATOR COMFORT AND CONTROLS

DESIGNED FOR SUCCESS

Ammann rollers are built to keep operators comfortable, helping boost productivity throughout a long shift. This attention to design also helps operators of all experience levels succeed.

## CABS AND PLATFORMS

- Spacious
- Comfortable
- Exceptional visibility
- Easy to operate
- Intuitive control and handling
- Easy-to-reach control switches



ARS cabin

# MAINTENANCE MADE EASY

MAKING THE MOST OF YOUR TIME

Extended service intervals limit the amount of routine maintenance that is required of all Ammann equipment. When it is time for preventive maintenance, service points are easy to reach – helping your crew quickly complete the work. Robust components minimise unplanned interruptions.

## KEY FEATURES

- All service points reachable from ground
- E-hydraulic tilt cab and hood standard on some models
- Filling and draining points centralised for easy and fast fluid exchange
- Convenient access to all filtration elements
- Cleanable, accessible cooler



# DRIVE TRAIN



Do you make a living on challenging jobsites with tough underfoot conditions and steep grades? These drive options can help.

### DRIVE (D)

- For machine with smooth drum and diamond tyres
- Gradeability of 45 %

### HX DRIVE (HX)

- HD propulsion plus reinforced front drive
- Gradeability of 65 %







# OPTIONS

## THE NEXT STEP

Finding the right roller is a great start. Next choose from a broad range of options that provide you with a machine that feels custom-made.

### LIGHT COMPACTORS

- 4-way dozer blade (ASC 30)
- PD drum for ASC 50
- Smooth drum shell kit
- Open platform
- Cabin
- Backup alarm
- Beacon
- Custom color



4-way dozer blade (ASC 30)



PD drum for ASC 50



Open platform



Cabin



## MEDIUM AND HEAVY COMPACTORS

- ACE<sup>pro</sup>/ACE<sup>force</sup>
- ACE GPS monitoring
- PD drum (or PD shell kit)
- ATC/HX versions
- ROPS/FOPS
- Cabin
- Air conditioning
- Radio with CD
- Ammann toolkit
- Dozer blade
- Road lighting
- Warning beacon
- Backup alarm
- Telematics-ready



ACE<sup>pro</sup> / ACE<sup>force</sup>



GPS monitoring



Dozer blade



Road lighting



Cabin

# DIMENSIONS

## ASC & ARS SINGLE DRUM ROLLERS

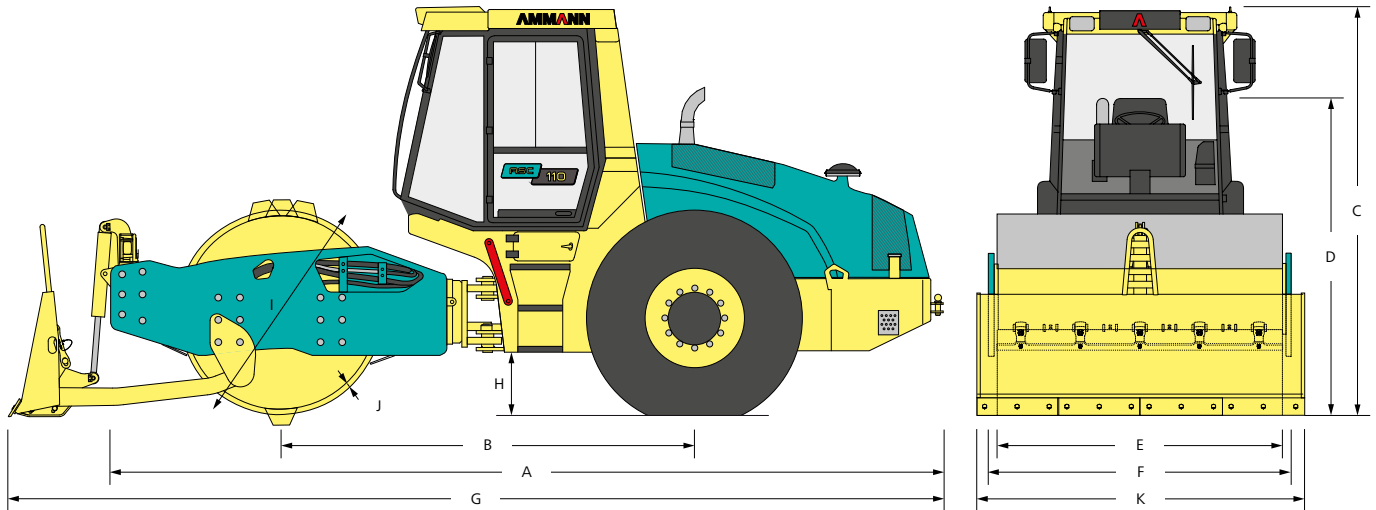

|   | ASC 30 T4i           | ASC 50 T4i                            | ASC 70 T3                             | ASC 70 T4f                            | ASC 100 T1                            |
|---|----------------------|---------------------------------------|---------------------------------------|---------------------------------------|---------------------------------------|
| A MACHINE LENGTH                        | 3190 mm (125.6 in)   | 3920 mm (154.4 in)                    | 5195 mm (204.6 in)                    | 5270 mm (207.5 in)                    | 5630 mm (221.7 in)                    |
| B WHEELBASE                             | 1770 mm (69.7 in)    | 2150 mm (85 in)                       | 2560 mm (100.8 in)                    | 2690 mm (106 in)                      | 2820 mm (111.1 in)                    |
| C MACHINE HEIGHT                        | 2470 mm (97.3 in)    | 2440 mm (96.1 in)                     | 2870 mm (113 in)                      | 2870 mm (113 in)                      | 3027 mm (119.2 in)                    |
| D MACHINE HEIGHT (REMOVED CAB / ROPS)   | -                    | -                                     | 2280 mm (89.8 in)                     | 2280 mm (89.8 in)                     | 2375 mm (93.6 in)                     |
| E DRUM WIDTH                            | 1200 mm (47.3 in)    | 1400 mm (55.2 in)                     | 1680 mm (66.2 in)                     | 1680 mm (66.2 in)                     | 2130 mm (83.9 in)                     |
| F MACHINE WIDTH                         | 1330 mm (52.4 in)    | 1540 mm (60.7 in)                     | 1720 mm (67.8 in)                     | 1875 mm (73.9 in)                     | 2250 mm (88.6 in)                     |
| G MACHINE LENGTH (BLADE) (D/ PD VERSIO) | 3920 mm (154.4 in)   | -                                     | - / 5555 mm (218.8 in)                | - / 5630 mm (221.7 in)                | -                                     |
| H GROUND CLEARANCE                      | 305 mm (12.1 in)     | 305 mm (12.1 in)                      | 385 mm (15.2 in)                      | 385 mm (15.2 in)                      | 450 mm (17.8 in)                      |
| I DRUM DIAMETER (D/ PD VERSIO)          | - / 890 mm (35.1 in) | 1080 mm (42.5 in) / 1104 mm (43.5 in) | 1300 mm (51.2 in) / 1400 mm (55.1 in) | 1300 mm (51.2 in) / 1400 mm (55.1 in) | 1500 mm (59.1 in) / 1640 mm (64.6 in) |
| J DRUM SHELL THICKNESS (D/ PD VERSIO)   | -                    | -                                     | 25 mm (1 in) / 15 mm (0.6 in)         | 25 mm (1 in) / 15 mm (0.6 in)         | 25 mm (1 in) / 20 mm (0.8 in)         |
| K MACHINE WIDTH (BLADE) (D/ PD VERSIO)  | 1450 mm (57.1 in)    | -                                     | - / 2215 mm (87.3 in)                 | - / 2215 mm (87.3 in)                 | -                                     |

|   | ASC 110 T3                            | ASC 110 T4i                           | ASC 120 T1                            | ASC 130 T3                            | ASC 130 T4i                           |
|---|---------------------------------------|---------------------------------------|---------------------------------------|---------------------------------------|---------------------------------------|
| A MACHINE LENGTH                        | 5780 mm (227.6 in)                    | 6050 mm (238.2 in)                    | 5630 mm (221.7 in)                    | 5780 mm (227.6 in)                    | 6050 mm (238.2 in)                    |
| B WHEELBASE                             | 2878 mm (113.4 in)                    | 2990 mm (117.7 in)                    | 2820 mm (111.1 in)                    | 2878 mm (113.4 in)                    | 2990 mm (117.8 in)                    |
| C MACHINE HEIGHT                        | 3070 mm (120.9 in)                    | 3070 mm (120.9 in)                    | 3027 mm (119.2 in)                    | 3070 mm (120.9 in)                    | 3070 mm (120.9 in)                    |
| D MACHINE HEIGHT (REMOVED CAB / ROPS)   | 2400 mm (94.5 in)                     | 2320 mm (91.3 in)                     | 2375 mm (93.6 in)                     | 2400 mm (94.5 in)                     | 2320 mm (91.4 in)                     |
| E DRUM WIDTH                            | 2130 mm (83.9 in)                     | 2130 mm (83.9 in)                     | 2130 mm (83.9 in)                     | 2130 mm (83.9 in)                     | 2130 mm (83.9 in)                     |
| F MACHINE WIDTH                         | 2258 mm (88.9 in)                     | 2260 mm (89 in)                       | 2250 mm (88.6 in)                     | 2258 mm (88.9 in)                     | 2260 mm (89 in)                       |
| G MACHINE LENGTH (BLADE) (D/ PD VERSIO) | - / 6557 mm (258.2 in)                | - / 6800 mm (267.8 in)                | -                                     | - / 6557 mm (258.2 in)                | - / 6800 mm (267.8 in)                |
| H GROUND CLEARANCE                      | 440 mm (17.4 in)                      | 440 mm (17.3 in)                      | 450 mm (17.8 in)                      | 430 mm (17 in)                        | 440 mm (17.4 in)                      |
| I DRUM DIAMETER (D/ PD VERSIO)          | 1500 mm (59.1 in) / 1640 mm (64.6 in) | 1500 mm (59.1 in) / 1640 mm (64.6 in) | 1500 mm (59.1 in) / 1640 mm (64.6 in) | 1500 mm (59.1 in) / 1640 mm (64.6 in) | 1500 mm (59.1 in) / 1640 mm (64.6 in) |
| J DRUM SHELL THICKNESS (D/ PD VERSIO)   | 25 mm (1 in) / 20 mm (0.8 in)         | 25 mm (1 in) / 20 mm (0.8 in)         | 25 mm (1 in) / 20 mm (0.8 in)         | 35 mm (1.4 in) / 25 mm (1 in)         | 35 mm (1.4 in) / 25 mm (1 in)         |
| K MACHINE WIDTH (BLADE) (D/ PD VERSIO)  | - / 2441 mm (96.2 in)                 | - / 2441 mm (96.2 in)                 | -                                     | - / 2441 mm (96.2 in)                 | - / 2441 mm (96.2 in)                 |



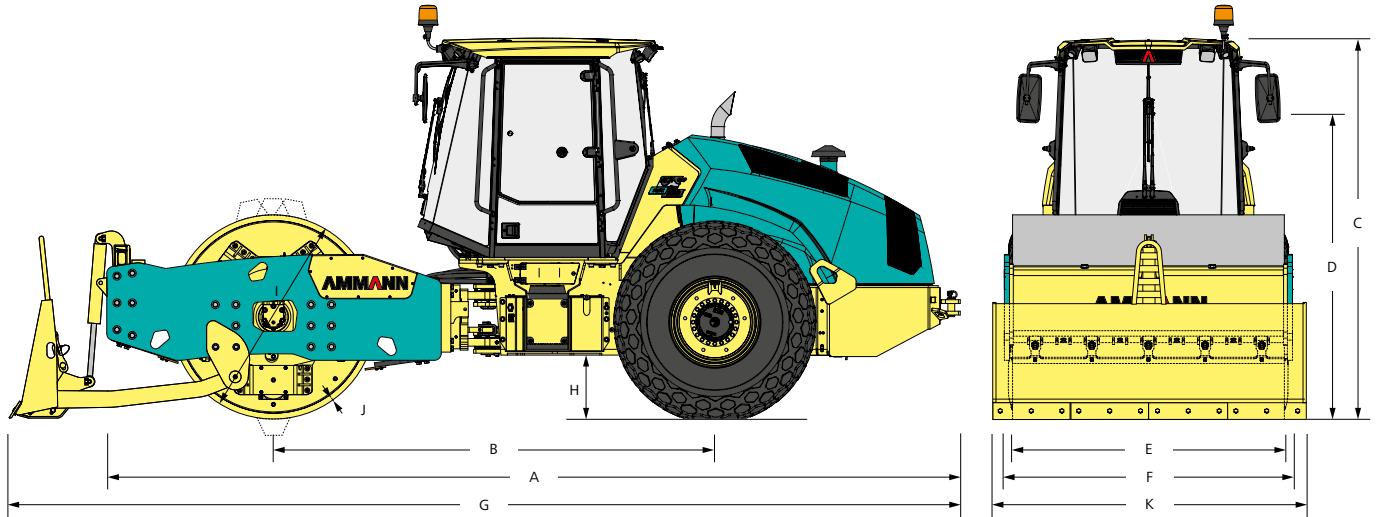

|   | ASC 150 T3                               | ASC 150 T4i                              | ASC 170 T3                               | ASC 170 T4i                              |
|---|--|--|--|--|
| A MACHINE LENGTH                        | 5900 mm (232.3 in)                       | 6130 mm (241.3 in)                       | 5900 mm (232.3 in)                       | 6135 mm (241.3 in)                       |
| B WHEELBASE                             | 2930 mm (115.4 in)                       | 3050 mm (120.1 in)                       | 2930 mm (115.4 in)                       | 3050 mm (120.1 in)                       |
| C MACHINE HEIGHT                        | 3075 mm (121.1 in)                       | 3070 mm (120.9 in)                       | 3075 mm (121.1 in)                       | 3070 mm (120.9 in)                       |
| D MACHINE HEIGHT (REMOVED CAB / ROPS)   | 2420 mm (95.3 in)                        | 2320 mm (91.3 in)                        | 2420 mm (95.3 in)                        | 2320 mm (91.3 in)                        |
| E DRUM WIDTH                            | 2130 mm (83.8 in)                        | 2130 mm (83.8 in)                        | 2130 mm (83.9 in)                        | 2130 mm (83.8 in)                        |
| F MACHINE WIDTH                         | 2258 mm (88.9 in)                        | 2258 mm (88.9 in)                        | 2258 mm (88.9 in)                        | 2258 mm (88.9 in)                        |
| G MACHINE LENGTH (BLADE) (D/ PD VERSIO) | - / 6650 mm (261.8 in)                   | - / 6850 mm (269.7 in)                   | - / - mm (- in)                          | - / 6850 mm (269.7 in)                   |
| H GROUND CLEARANCE                      | 440 mm (17.3 in)                         | 440 mm (17.3 in)                         | 440 mm (17.4 in)                         | 440 mm (17.3 in)                         |
| I DRUM DIAMETER (D/ PD VERSIO)          | 1500 mm (59.1 in)<br>/ 1640 mm (64.6 in) | 1500 mm (59.1 in)<br>/ 1640 mm (64.6 in) | 1500 mm (59.1 in)<br>/ 1640 mm (64.6 in) | 1500 mm (59.1 in)<br>/ 1640 mm (64.6 in) |
| J DRUM SHELL THICKNESS (D/ PD VERSIO)   | 40 mm (1.6 in)<br>/ 28 mm (1.1 in)       | 40 mm (1.6 in)<br>/ 28 mm (1.1 in)       | 40 mm (1.6 in)<br>/ 28 mm (1.1 in)       | 40 mm (1.6 in)<br>/ 28 mm (1.1 in)       |
| K MACHINE WIDTH (BLADE) (D/ PD VERSIO)  | - / 2441 mm (96.1 in)                    | - / 2441 mm (96.1 in)                    | - / - mm (- in)                          | - / 2441 mm (96.1 in)                    |

|   | ARS 200 T3                               | ARS 200 T4f                              | ARS 220 T3                               | ARS 220 T4f                              |
|---|--|--|--|--|
| A MACHINE LENGTH                        | 6688 mm (260.8 in)                       | 6688 mm (260.8 in)                       | 6730 mm (265 in)                         | 6730 mm (265 in)                         |
| B WHEELBASE                             | 3460 mm (135 in)                         | 3460 mm (135 in)                         | 3510 mm (138.2 in)                       | 3510 mm (138.2 in)                       |
| C MACHINE HEIGHT                        | 2985 mm (116.4 in)                       | 2985 mm (116.4 in)                       | 2950 mm (116.1 in)                       | 2950 mm (116.1 in)                       |
| D MACHINE HEIGHT (REMOVED CAB / ROPS)   | 2565 mm (100 in)                         | 2565 mm (100 in)                         | 2250 mm (88.6 in)                        | 2250 mm (88.6 in)                        |
| E DRUM WIDTH                            | 2130 mm (83 in)                          | 2130 mm (83 in)                          | 2130 mm (83 in)                          | 2130 mm (83 in)                          |
| F MACHINE WIDTH                         | 2258 mm (88 in)                          | 2258 mm (88 in)                          | 2300 mm (90.6 in)                        | 2300 mm (90.6 in)                        |
| G MACHINE LENGTH (BLADE) (D/ PD VERSIO) | - / 7496 mm (292.3 in)                   | - / 7496 mm (292.3 in)                   | - / 7575 mm (298.2 in)                   | - / 7575 mm (298.2 in)                   |
| H GROUND CLEARANCE                      | 500 mm (19.5 in)                         | 500 mm (19.5 in)                         | 500 mm (19.5 in)                         | 500 mm (19.5 in)                         |
| I DRUM DIAMETER (D/ PD VERSIO)          | 1600 mm (62.4 in)<br>/ 1795 mm (62.4 in) | 1600 mm (62.4 in)<br>/ 1795 mm (62.4 in) | 1600 mm (62.4 in)<br>/ 1795 mm (62.4 in) | 1600 mm (62.4 in)<br>/ 1795 mm (62.4 in) |
| J DRUM SHELL THICKNESS (D/ PD VERSIO)   | 45 mm (1.8 in)<br>/ 30 mm (1.8 in)       | 45 mm (1.8 in)<br>/ 30 mm (1.8 in)       | 45 mm (1.8 in)<br>/ 30 mm (1.8 in)       | 45 mm (1.8 in)<br>/ 30 mm (1.8 in)       |
| K MACHINE WIDTH (BLADE) (D/ PD VERSIO)  | - / 2441 mm (95.2 in)                    | - / 2441 mm (95.2 in)                    | - / 2450 mm (96.5 in)                    | - / 2450 mm (96.5 in)                    |

# SPECIFICATIONS

## ASC SINGLE DRUM ROLLERS SMOOTH DRUM



|  | ASC 30                | ASC 50 | ASC 70 | ASC 70 | ASC 100 |
|--|-----------------------|--------|--------|--------|---------|
|  | Smooth drum shell kit | T4i    | T3     | T4f    | T1      |

### MISCELLANEOUS

|                    |   |                            |                            |                            |                            |
|--------------------|---|----------------------------|----------------------------|----------------------------|----------------------------|
| BRAKES OPERATING   | – | Hydrostatic                | Hydrostatic                | Hydrostatic                | Hydrostatic                |
| BRAKES PARKING     | – | Multiple-disc spring brake | Multiple-disc spring brake | Multiple-disc spring brake | Multiple-disc spring brake |
| BRAKES EMERGENCY   | – | Multiple-disc spring brake | Multiple-disc spring brake | Multiple-disc spring brake | Multiple-disc spring brake |
| FUEL TANK CAPACITY | – | 78 l (20.6 gal)            | 275 l (72.65 gal)          | 255 l (67.36 gal)          | 410 l (108.3 gal)          |
| VOLTAGE            | – | 12 V                       | 24 V                       | 24 V                       | 24 V                       |

### COMPACTION FORCES

|                              |   |                  |                    |                    |                    |
|------------------------------|---|------------------|--------------------|--------------------|--------------------|
| FREQUENCY I                  | – | 34 Hz (2040 VPM) | 30 Hz (1800 VPM)   | 30 Hz (1800 VPM)   | 32 Hz (1920 VPM)   |
| FREQUENCY II                 | – | 37 Hz (2220 VPM) | 41 Hz (2460 VPM)   | 41 Hz (2460 VPM)   | 35 Hz (2100 VPM)   |
| FREQUENCY ACE MIN./MAX.      | – | –                | –                  | –                  | –                  |
| AMPLITUDE I                  | – | 1.8 mm (0.07 in) | 1.7 mm (0.067 in)  | 1.7 mm (0.067 in)  | 1.85 mm (0.073 in) |
| AMPLITUDE II                 | – | 0.8 mm (0.03 in) | 0.86 mm (0.034 in) | 0.86 mm (0.034 in) | 1.15 mm (0.045 in) |
| AMPLITUDE ACE MIN./MAX.      | – | –                | –                  | –                  | –                  |
| CENTRIFUGAL FORCE I          | – | 40 kN            | 145 kN             | 145 kN             | 277 kN             |
| CENTRIFUGAL FORCE II         | – | 100 kN           | 130 kN             | 130 kN             | 206 kN             |
| CENTRIF. FORCE ACE MIN./MAX. | – | –                | –                  | –                  | –                  |

### ENGINE

|   |   |                                 |                                |                                 |                             |
|---|---|---------------------------------|--------------------------------|---------------------------------|-----------------------------|
| MANUFACTURER                              | – | Kubota V3600                    | Cummins QSB 3.3-C99            | Deutz TCD3.6 L4                 | Cummins 4BTA 3.9-C116       |
| POWER ACCORDING TO ISO 3046-1             | – | 35.9 kW (48 HP)                 | 74 kW (99 HP)                  | 55.4 kW (75 HP)                 | 86 kW (115 HP)              |
| MAXIMUM TORQUE                            | – | 221/1600 Nm/rpm                 | 412/1600 Nm/rpm                | 390/1300 Nm/rpm                 | 423/1500 Nm/rpm             |
| ENGINE COMPLIES WITH EMISSION REGULATIONS | – | EU Stage IIIA, U.S. EPA Tier 4i | EU Stage IIIA, U.S. EPA Tier 3 | EU Stage IIIB, U.S. EPA Tier 4f | EU Stage I, U.S. EPA Tier 1 |
| ROAD CONSTRUCTION TECHNOLOGY              | – | –                               | ACE <sup>force</sup>           | ACE <sup>force</sup>            | –                           |

### WEIGHT & OPERATING CHARACTERISTICS

|                             |   |                        |                          |                          |                          |
|-----------------------------|---|------------------------|--------------------------|--------------------------|--------------------------|
| OPERATING WEIGHT            | – | 4500 kg (9920 lb)      | 7140 kg (15740 lb)       | 7240 kg (15960 lb)       | 10 120 kg (22310 lb)     |
| MAXIMUM WEIGHT              | – | 5000 kg (11 020 lb)    | 9260 kg (20 410 lb)      | 9360 kg (20 640 lb)      | 11 990 kg (26 430 lb)    |
| STATIC LINEAR LOAD          | – | 17.3 kg/cm (100 lb/in) | 23.9 kg/cm (133.8 lb/in) | 23.7 kg/cm (132.7 lb/in) | 24.9 kg/cm (139.4 lb/in) |
| MAX. TRANSPORT SPEED        | – | 7.5 km/h (4.7 MPH)     | 11 km/h (6.8 MPH)        | 11.4 km/h (7.1 MPH)      | 10.3 km/h (6.4 MPH)      |
| MAX. WORKING SPEED          | – | –                      | 4.7 km/h (2.9 MPH)       | 5.1 km/h (3.2 MPH)       | 7.1 km/h (4.4 MPH)       |
| CLIMBING ABILITY            | – | 40 %                   | 45 %                     | 45 %                     | 40 %                     |
| TURNING RADIUS INNER (EDGE) | – | 3600 mm (141.7 in)     | 3090 mm (121.7 in)       | 3200 mm (126 in)         | 3210 mm (126.4 in)       |



## ASC SINGLE DRUM ROLLERS PADFOOT DRUM



|  | ASC 30 | ASC 50 | ASC 70 | ASC 70 | ASC 100 |
|--|--------|--------|--------|--------|---------|
|  | T4i    | T4i    | T3     | T4f    | T1      |

### MISCELLANEOUS

|                    |                            |                            |                            |                            |                            |
|--------------------|----------------------------|----------------------------|----------------------------|----------------------------|----------------------------|
| BRAKES OPERATING   | Hydrostatic                | Hydrostatic                | Hydrostatic                | Hydrostatic                | Hydrostatic                |
| BRAKES PARKING     | Multiple-disc spring brake | Multiple-disc spring brake | Multiple-disc spring brake | Multiple-disc spring brake | Multiple-disc spring brake |
| BRAKES EMERGENCY   | Multiple-disc spring brake | Multiple-disc spring brake | Multiple-disc spring brake | Multiple-disc spring brake | Multiple-disc spring brake |
| FUEL TANK CAPACITY | 78 l (20.6 gal)            | 78 l (20.6 gal)            | 275 l (72.65 gal)          | 255 l (67.36 gal)          | 410 l (108.3 gal)          |
| VOLTAGE            | 12 V                       | 12 V                       | 24 V                       | 24 V                       | 24 V                       |

### COMPACTION FORCES

|                              |                  |                  |                    |                    |                    |
|------------------------------|------------------|------------------|--------------------|--------------------|--------------------|
| FREQUENCY I                  | –                | –                | 30 Hz (1800 VPM)   | 30 Hz (1800 VPM)   | 32 Hz (1920 VPM)   |
| FREQUENCY II                 | 36 Hz (2160 VPM) | 34 Hz (2040 VPM) | 41 Hz (2460 VPM)   | 41 Hz (2460 VPM)   | 35 Hz (2100 VPM)   |
| FREQUENCY ACE MIN./MAX.      | –                | –                | –                  | –                  | –                  |
| AMPLITUDE I                  | 1.8 mm (0.07 in) | 1.8 mm (0.07 in) | 1.7 mm (0.067 in)  | 1.7 mm (0.067 in)  | 1.6 mm (0.063 in)  |
| AMPLITUDE II                 | –                | –                | 0.86 mm (0.034 in) | 0.86 mm (0.034 in) | 0.97 mm (0.038 in) |
| AMPLITUDE ACE MIN./MAX.      | –                | –                | –                  | –                  | –                  |
| CENTRIFUGAL FORCE I          | 85 kN            | 100 kN           | 145 kN             | 145 kN             | 277 kN             |
| CENTRIFUGAL FORCE II         | –                | –                | 130 kN             | 130 kN             | 206 kN             |
| CENTRIF. FORCE ACE MIN./MAX. | –                | –                | –                  | –                  | –                  |

### ENGINE

| MANUFACTURER                              | Kubota V2203 M                  | Kubota V3600                    | Cummins QSB 3.3-C99            | Deutz TCD3.6 L4                 | Cummins 4BTA 3.9-C116       |
|---|---------------------------------|---------------------------------|--------------------------------|---------------------------------|-----------------------------|
| POWER ACCORDING TO ISO 3046-1             | 35.9 kW (48 HP)                 | 49.8 kW (67 HP)                 | 74 kW (99 HP)                  | 55.4 kW (75 HP)                 | 86 kW (115 HP)              |
| MAXIMUM TORQUE                            | 143.2/1600 Nm/rpm               | 221/1600 Nm/rpm                 | 412/1600 Nm/rpm                | 390/1300 Nm/rpm                 | 423/1500 Nm/rpm             |
| ENGINE COMPLIES WITH EMISSION REGULATIONS | EU Stage IIIA, U.S. EPA Tier 4i | EU Stage IIIA, U.S. EPA Tier 4i | EU Stage IIIA, U.S. EPA Tier 3 | EU Stage IIIB, U.S. EPA Tier 4f | EU Stage I, U.S. EPA Tier 1 |
| ROAD CONSTRUCTION TECHNOLOGY              | –                               | –                               | ACE <sup>force</sup>           | ACE <sup>force</sup>            | –                           |

### WEIGHT & OPERATING CHARACTERISTICS

|                             |                    |                     |                     |                     |                       |
|-----------------------------|--------------------|---------------------|---------------------|---------------------|-----------------------|
| OPERATING WEIGHT            | 4100 kg (9040 lb)  | 4500 kg (9920 lb)   | 7090 kg (15 630 lb) | 7090 kg (15 630 lb) | 10 860 kg (23 940 lb) |
| MAXIMUM WEIGHT              | 4470 kg (9850 lb)  | 5000 kg (11 020 lb) | 8120 kg (17 900 lb) | 8120 kg (17 900 lb) | 11 030 kg (24 320 lb) |
| STATIC LINEAR LOAD          | –                  | –                   | –                   | –                   | –                     |
| MAX. TRANSPORT SPEED        | 4.2 km/h (2.6 MPH) | 7.5 km/h (4.7 MPH)  | 11.1 km/h (6.9 MPH) | 11.1 km/h (6.9 MPH) | 10.3 km/h (6.4 MPH)   |
| MAX. WORKING SPEED          | –                  | –                   | 4.8 km/h (3 MPH)    | 4.8 km/h (3 MPH)    | 7.1 km/h (4.4 MPH)    |
| CLIMBING ABILITY            | 40 %               | 40 %                | 45 %                | 45 %                | 40 %                  |
| TURNING RADIUS INNER (EDGE) | 2700 mm (106.3 in) | 3600 mm (141.7 in)  | 3090 mm (121.7 in)  | 3200 mm (126 in)    | 3210 mm (126.4 in)    |

# SPECIFICATIONS

## ASC SINGLE DRUM ROLLERS SMOOTH DRUM



|  | ASC 110 | ASC 110 | ASC 120 | ASC 130 | ASC 130 |
|--|---------|---------|---------|---------|---------|
|  | T3      | T4i     | T1      | T3      | T4i     |

### MISCELLANEOUS

|                    |                            |                            |                            |                            |                            |
|--------------------|----------------------------|----------------------------|----------------------------|----------------------------|----------------------------|
| BRAKES OPERATING   | Hydrostatic                | Hydrostatic                | Hydrostatic                | Hydrostatic                | Hydrostatic                |
| BRAKES PARKING     | Multiple-disc spring brake | Multiple-disc spring brake | Multiple-disc spring brake | Multiple-disc spring brake | Multiple-disc spring brake |
| BRAKES EMERGENCY   | Multiple-disc spring brake | Multiple-disc spring brake | Multiple-disc spring brake | Multiple-disc spring brake | Multiple-disc spring brake |
| FUEL TANK CAPACITY | 410 l (108.3 gal)          | 350 l (92.5 gal)           | 410 l (108.3 gal)          | 410 l (108.3 gal)          | 350 l (92.5 gal)           |
| VOLTAGE            | 24 V                       | 24 V                       | 24 V                       | 24 V                       | 24 V                       |

### COMPACTION FORCES

|                              |  |  |                    |                    |                    |
|------------------------------|--|--|--------------------|--------------------|--------------------|
| FREQUENCY I                  | 32 Hz (1920 VPM)                       | 32 Hz (1920 VPM)                       | 32 Hz (1920 VPM)   | 30 Hz (1800 VPM)   | 32 Hz (1920 VPM)   |
| FREQUENCY II                 | 35 Hz (2100 VPM)                       | 35 Hz (2100 VPM)                       | 35 Hz (2100 VPM)   | 36 Hz (2160 VPM)   | 35 Hz (2100 VPM)   |
| FREQUENCY ACE MIN./MAX.      | 23 Hz (1380 VPM)<br>/ 35 Hz (2100 VPM) | 23 Hz (1380 VPM)<br>/ 35 Hz (2100 VPM) | –                  | –                  | –                  |
| AMPLITUDE I                  | 0.9 mm (0.035 in)                      | 1.15 mm (0.045 in)                     | 1.65 mm (0.065 in) | 1.9 mm (0.075 in)  | 1.15 mm (0.045 in) |
| AMPLITUDE II                 | 1.85 mm (0.073 in)                     | 1.85 mm (0.073 in)                     | 0.95 mm (0.037 in) | 1.05 mm (0.041 in) | 1.86 mm (0.073 in) |
| AMPLITUDE ACE MIN./MAX.      | 0 mm (0 in)<br>/ 2.5 mm (0.098 in)     | 0 mm (0 in)<br>/ 2.5 mm (0.098 in)     | –                  | –                  | –                  |
| CENTRIFUGAL FORCE I          | 206 kN                                 | 206 kN                                 | 277 kN             | 300 kN             | 206 kN             |
| CENTRIFUGAL FORCE II         | 277 kN                                 | 277 kN                                 | 206 kN             | 230 kN             | 277 kN             |
| CENTRIF. FORCE ACE MIN./MAX. | 0 kN / 280 kN                          | 0 / 280 kN                             | –                  | –                  | –                  |

### ENGINE

|   |   |   |                                |                                   |                                    |
|---|---|---|--------------------------------|-----------------------------------|------------------------------------|
| MANUFACTURER                              | Cummins<br>QSB 4.5-C160                   | Cummins<br>QSB 4.5-C160                   | Cummins<br>4BTA 3.9-C116       | Cummins<br>QSB 4.5-C160           | Cummins<br>QSB 4.5-C160            |
| POWER ACCORDING TO ISO 3046-1             | 119 kW (160 HP)                           | 119 kW (160 HP)                           | 86 kW (115 HP)                 | 119 kW (160 HP)                   | 119 kW (160 HP)                    |
| MAXIMUM TORQUE                            | 624/1500 Nm/rpm                           | 624/1500 Nm/rpm                           | 423/1500 Nm/rpm                | 624/1500 Nm/rpm                   | 624/1500 Nm/rpm                    |
| ENGINE COMPLIES WITH EMISSION REGULATIONS | EU Stage IIIA,<br>U.S. EPA Tier 3         | EU Stage IIIB,<br>U.S. EPA Tier 4i        | EU Stage I,<br>U.S. EPA Tier 1 | EU Stage IIIA,<br>U.S. EPA Tier 3 | EU Stage IIIB,<br>U.S. EPA Tier 4i |
| ROAD CONSTRUCTION TECHNOLOGY              | ACE <sup>pro</sup> / ACE <sup>force</sup> | ACE <sup>pro</sup> / ACE <sup>force</sup> | –                              | ACE <sup>force</sup>              | ACE <sup>force</sup>               |

### WEIGHT & OPERATING CHARACTERISTICS

|                             |                             |                           |                             |                           |                             |
|-----------------------------|-----------------------------|---------------------------|-----------------------------|---------------------------|-----------------------------|
| OPERATING WEIGHT            | 11 490 kg (25 330 lb)       | 11 570 kg (25 510 lb)     | 11 500 kg (25 350 lb)       | 12 510 kg (27 580 lb)     | 12 620 kg (27 820 lb)       |
| MAXIMUM WEIGHT              | 15 370 kg (33 890 lb)       | 15 430 kg (34 020 lb)     | 13 370 kg (29 480 lb)       | 16 390 kg (36 130 lb)     | 16 480 kg (36 330 lb)       |
| STATIC LINEAR LOAD          | 34.5 kg/cm<br>(193.2 lb/in) | 33.4 kg/cm<br>(187 lb/in) | 29.8 kg/cm<br>(166.9 lb/in) | 39.1 kg/cm<br>(219 lb/in) | 38.7 kg/cm<br>(216.7 lb/in) |
| MAX. TRANSPORT SPEED        | 12.8 km/h (8 MPH)           | 12.5 km/h (7.8 MPH)       | 10.3 km/h (6.4 MPH)         | 13 km/h (8.08 MPH)        | 12.5 km/h (7.8 MPH)         |
| MAX. WORKING SPEED          | 5.6 km/h (3.5 MPH)          | 5.7 km/h (3.5 MPH)        | 7.1 km/h (4.4 MPH)          | 5.6 km/h (3.48 MPH)       | 5.7 km/h (3.5 MPH)          |
| CLIMBING ABILITY            | 45 %                        | 45 %                      | 40 %                        | 45 %                      | 45 %                        |
| TURNING RADIUS INNER (EDGE) | 3050 mm (120.1 in)          | 3630 mm (142.9 in)        | 3210 mm (126.4 in)          | 3050 mm (120.1 in)        | 3630 mm (142.9 in)          |



## ASC SINGLE DRUM ROLLERS PADFOOT DRUM



|  | ASC 110 | ASC 110 | ASC 120 | ASC 130 | ASC 130 |
|--|---------|---------|---------|---------|---------|
|  | T3      | T4i     | T1      | T3      | T4i     |

### MISCELLANEOUS

|                    |                            |                            |                            |                            |                            |
|--------------------|----------------------------|----------------------------|----------------------------|----------------------------|----------------------------|
| BRAKES OPERATING   | Hydrostatic                | Hydrostatic                | Hydrostatic                | Hydrostatic                | Hydrostatic                |
| BRAKES PARKING     | Multiple-disc spring brake | Multiple-disc spring brake | Multiple-disc spring brake | Multiple-disc spring brake | Multiple-disc spring brake |
| BRAKES EMERGENCY   | Multiple-disc spring brake | Multiple-disc spring brake | Multiple-disc spring brake | Multiple-disc spring brake | Multiple-disc spring brake |
| FUEL TANK CAPACITY | 410 l (108.3 gal)          | 350 l (92.5 gal)           | 410 l (108.3 gal)          | 410 l (108.3 gal)          | 350 l (92.5 gal)           |
| VOLTAGE            | 24 V                       | 24 V                       | 24 V                       | 24 V                       | 24 V                       |

### COMPACTION FORCES

|                              |                                     |                                     |                    |                    |                   |
|------------------------------|-------------------------------------|-------------------------------------|--------------------|--------------------|-------------------|
| FREQUENCY I                  | 31 Hz (1860 VPM)                    | 31 Hz (1860 VPM)                    | 32 Hz (1920 VPM)   | 30 Hz (1800 VPM)   | 31 Hz (1860 VPM)  |
| FREQUENCY II                 | 35 Hz (2100 VPM)                    | 35 Hz (2100 VPM)                    | 35 Hz (2100 VPM)   | 36 Hz (2160 VPM)   | 35 Hz (2100 VPM)  |
| FREQUENCY ACE MIN./MAX.      | 23 Hz (1380 VPM) / 35 Hz (2100 VPM) | 23 Hz (1380 VPM) / 35 Hz (2100 VPM) | –                  | –                  | –                 |
| AMPLITUDE I                  | 1.1 mm (0.043 in)                   | 1.1 mm (0.043 in)                   | 1.55 mm (0.061 in) | 1.85 mm (0.073 in) | 1.1 mm (0.043 in) |
| AMPLITUDE II                 | 2 mm (0.079 in)                     | 2 mm (0.079 in)                     | 0.9 mm (0.035 in)  | 1 mm (0.039 in)    | 2 mm (0.079 in)   |
| AMPLITUDE ACE MIN./MAX.      | 0 mm (0 in) / 2.5 mm (0.098 in)     | 0 mm (0 in) / 2.5 mm (0.098 in)     | –                  | –                  | –                 |
| CENTRIFUGAL FORCE I          | 220 kN                              | 220 kN                              | 277 kN             | 300 kN             | 220 kN            |
| CENTRIFUGAL FORCE II         | 277 kN                              | 315 kN                              | 206 kN             | 230 kN             | 315 kN            |
| CENTRIF. FORCE ACE MIN./MAX. | 0 kN / 280 kN                       | 0 / 280 kN                          | –                  | –                  | –                 |

### ENGINE

|   |   |   |                             |                                |                                 |
|---|---|---|-----------------------------|--------------------------------|---------------------------------|
| MANUFACTURER                              | Cummins QSB 4.5-C160                      | Cummins QSB 4.5-C160                      | Cummins 4BTA 3.9-C116       | Cummins QSB 4.5-C160           | Cummins QSB 4.5-C160            |
| POWER ACCORDING TO ISO 3046-1             | 119 kW (160 HP)                           | 119 kW (160 HP)                           | 86 kW (115 HP)              | 119 kW (160 HP)                | 119 kW (160 HP)                 |
| MAXIMUM TORQUE                            | 624/1500 Nm/rpm                           | 624/1500 Nm/rpm                           | 423/1500 Nm/rpm             | 624/1500 Nm/rpm                | 624/1500 Nm/rpm                 |
| ENGINE COMPLIES WITH EMISSION REGULATIONS | EU Stage IIIA, U.S. EPA Tier 3            | EU Stage IIIB, U.S. EPA Tier 4i           | EU Stage I, U.S. EPA Tier 1 | EU Stage IIIA, U.S. EPA Tier 3 | EU Stage IIIB, U.S. EPA Tier 4i |
| ROAD CONSTRUCTION TECHNOLOGY              | ACE <sup>pro</sup> / ACE <sup>force</sup> | ACE <sup>pro</sup> / ACE <sup>force</sup> | –                           | ACE <sup>force</sup>           | ACE <sup>force</sup>            |

### WEIGHT & OPERATING CHARACTERISTICS

|                             |                       |                       |                       |                       |                       |
|-----------------------------|-----------------------|-----------------------|-----------------------|-----------------------|-----------------------|
| OPERATING WEIGHT            | 12 100 kg (26 680 lb) | 12 180 kg (26 850 lb) | 12 060 kg (26 590 lb) | 12 740 kg (28 090 lb) | 12 840 kg (28 310 lb) |
| MAXIMUM WEIGHT              | 14 280 kg (31 480 lb) | 14 340 kg (31 610 lb) | 12 230 kg (26 960 lb) | 14 920 kg (32 890 lb) | 15 000 kg (33 070 lb) |
| STATIC LINEAR LOAD          | –                     | –                     | –                     | –                     | –                     |
| MAX. TRANSPORT SPEED        | 12.8 km/h (8 MPH)     | 12.5 km/h (7.8 MPH)   | 10.3 km/h (6.4 MPH)   | 12.8 km/h (7.95 MPH)  | 12.5 km/h (7.8 MPH)   |
| MAX. WORKING SPEED          | 5.6 km/h (3.5 MPH)    | 5.7 km/h (3.5 MPH)    | 7.1 km/h (4.4 MPH)    | 5.6 km/h (3.48 MPH)   | 5.7 km/h (3.5 MPH)    |
| CLIMBING ABILITY            | 45 %                  | 45 %                  | 40 %                  | 45 %                  | 45 %                  |
| TURNING RADIUS INNER (EDGE) | 3050 mm (120.1 in)    | 3630 mm (142.9 in)    | 3210 mm (126.4 in)    | 3050 mm (120.1 in)    | 3630 mm (142.9 in)    |

# SPECIFICATIONS

## ASC SINGLE DRUM ROLLERS SMOOTH DRUM



|  | ASC 150 | ASC 150 | ASC 170 | ASC 170 |
|--|---------|---------|---------|---------|
|  | T3      | T4i     | T3      | T4i     |

### MISCELLANEOUS

|                    |                            |                            |                            |                            |
|--------------------|----------------------------|----------------------------|----------------------------|----------------------------|
| BRAKES OPERATING   | Hydrostatic                | Hydrostatic                | Hydrostatic                | Hydrostatic                |
| BRAKES PARKING     | Multiple-disc spring brake | Multiple-disc spring brake | Multiple-disc spring brake | Multiple-disc spring brake |
| BRAKES EMERGENCY   | Multiple-disc spring brake | Multiple-disc spring brake | Multiple-disc spring brake | Multiple-disc spring brake |
| FUEL TANK CAPACITY | 410 l (108.3 gal)          | 350 l (92.5 gal)           | 410 l (108.3 gal)          | 350 l (92.5 gal)           |
| VOLTAGE            | 24 V                       | 24 V                       | 24 V                       | 24 V                       |

### COMPACTION FORCES

|                              |   |                  |                   |                   |
|------------------------------|---|------------------|-------------------|-------------------|
| FREQUENCY I                  | 29 Hz (1740 VPM)                        | 29 Hz (1740 VPM) | 28 Hz (1680 VPM)  | 28 Hz (1680 VPM)  |
| FREQUENCY II                 | 35 Hz (2100 VPM)                        | 35 Hz (2100 VPM) | 35 Hz (2100 VPM)  | 35 Hz (2100 VPM)  |
| FREQUENCY ACE MIN./MAX.      | 23 Hz (13800 VPM)<br>/ 35 Hz (2100 VPM) | -                | -                 | -                 |
| AMPLITUDE I                  | 2 mm (0.079 in)                         | 2 mm (0.079 in)  | 2.2 mm (0.087 in) | 2.2 mm (0.087 in) |
| AMPLITUDE II                 | 1 mm (0.039 in)                         | 1 mm (0.039 in)  | 1.2 mm (0.047 in) | 1.1 mm (0.043 in) |
| AMPLITUDE ACE MIN./MAX.      | -<br>/ 2.5 mm (0.098 in)                | -                | -                 | -                 |
| CENTRIFUGAL FORCE I          | 325 kN                                  | 325 kN           | 335 kN            | 335 kN            |
| CENTRIFUGAL FORCE II         | 237 kN                                  | 237 kN           | 260 kN            | 260 kN            |
| CENTRIF. FORCE ACE MIN./MAX. | - / 388/26 Hz                           | -                | -                 | -                 |

### ENGINE

|   |   |   |                                   |                                    |
|---|---|---|-----------------------------------|------------------------------------|
| MANUFACTURER                              | Cummins<br>QSB 4.5-C160                   | Cummins<br>QSB 4.5-C160                   | Cummins<br>QSB 4.5-C160           | Cummins<br>QSB 4.5-C160            |
| POWER ACCORDING TO ISO 3046-1             | 119 kW (160 HP)                           | 119 kW (160 HP)                           | 119 kW (160 HP)                   | 119 kW (160 HP)                    |
| MAXIMUM TORQUE                            | 624/1500 Nm/rpm                           | 624/1500 Nm/rpm                           | 624/1500 Nm/rpm                   | 624/1500 Nm/rpm                    |
| ENGINE COMPLIES WITH EMISSION REGULATIONS | EU Stage IIIA,<br>U.S. EPA Tier 3         | EU Stage IIIB,<br>U.S. EPA Tier 4i        | EU Stage IIIA,<br>U.S. EPA Tier 3 | EU Stage IIIB,<br>U.S. EPA Tier 4i |
| ROAD CONSTRUCTION TECHNOLOGY              | ACE <sup>pro</sup> / ACE <sup>force</sup> | ACE <sup>pro</sup> / ACE <sup>force</sup> | ACE <sup>force</sup>              | ACE <sup>force</sup>               |

### WEIGHT & OPERATING CHARACTERISTICS

|                             |                             |                           |                             |                             |
|-----------------------------|-----------------------------|---------------------------|-----------------------------|-----------------------------|
| OPERATING WEIGHT            | 14 580 kg (32 140 lb)       | 14 580 kg (32 140 lb)     | 16 270 kg (35 870 lb)       | 16 000 kg (35 270 lb)       |
| MAXIMUM WEIGHT              | 18 460 kg (40 700 lb)       | 18 440 kg (40 650 lb)     | 18 140 kg (39 990 lb)       | 17 850 kg (39 350 lb)       |
| STATIC LINEAR LOAD          | 48.7 kg/cm<br>(272.7 lb/in) | 47.5 kg/cm<br>(266 lb/in) | 51.9 kg/cm<br>(290.6 lb/in) | 50.5 kg/cm<br>(282.8 lb/in) |
| MAX. TRANSPORT SPEED        | 10 km/h (6.21 MPH)          | 10 km/h (6.21 MPH)        | 10 km/h (6.21 MPH)          | 10 km/h (6.21 MPH)          |
| MAX. WORKING SPEED          | 4.5 km/h (2.8 MPH)          | 4.5 km/h (2.8 MPH)        | 4.5 km/h (2.8 MPH)          | 4.5 km/h (2.8 MPH)          |
| CLIMBING ABILITY            | 45 %                        | 45 %                      | 30 %                        | 53 %                        |
| TURNING RADIUS INNER (EDGE) | 3715 mm (146.3 in)          | 3715 mm (146.3 in)        | 3715 mm (146.3 in)          | 3715 mm (146.3 in)          |



## ASC SINGLE DRUM ROLLERS PADFOOT DRUM



|  | ASC 150 | ASC 150 | ASC 170 | ASC 170 |
|--|---------|---------|---------|---------|
|  | T3      | T4i     | T3      | T4i     |

### MISCELLANEOUS

|                    |                            |                            |                            |                            |
|--------------------|----------------------------|----------------------------|----------------------------|----------------------------|
| BRAKES OPERATING   | Hydrostatic                | Hydrostatic                | Hydrostatic                | Hydrostatic                |
| BRAKES PARKING     | Multiple-disc spring brake | Multiple-disc spring brake | Multiple-disc spring brake | Multiple-disc spring brake |
| BRAKES EMERGENCY   | Multiple-disc spring brake | Multiple-disc spring brake | Multiple-disc spring brake | Multiple-disc spring brake |
| FUEL TANK CAPACITY | 410 l (108.3 gal)          | 350 l (92.5 gal)           | 410 l (108.3 gal)          | 350 l (92.5 gal)           |
| VOLTAGE            | 24 V                       | 24 V                       | 24 V                       | 24 V                       |

### COMPACTION FORCES

|                              |                                      |                  |                   |                   |
|------------------------------|--------------------------------------|------------------|-------------------|-------------------|
| FREQUENCY I                  | 29 Hz (1740 VPM)                     | 29 Hz (1740 VPM) | 28 Hz (1680 VPM)  | 28 Hz (1680 VPM)  |
| FREQUENCY II                 | 35 Hz (2100 VPM)                     | 35 Hz (2100 VPM) | 35 Hz (2100 VPM)  | 35 Hz (2100 VPM)  |
| FREQUENCY ACE MIN./MAX.      | 23 Hz (13800 VPM) / 35 Hz (2100 VPM) | -                | -                 | -                 |
| AMPLITUDE I                  | 2 mm (0.079 in)                      | 2 mm (0.079 in)  | 2.2 mm (0.087 in) | 2.2 mm (0.087 in) |
| AMPLITUDE II                 | 1 mm (0.039 in)                      | 1 mm (0.039 in)  | 1.1 mm (0.043 in) | 1.1 mm (0.043 in) |
| AMPLITUDE ACE MIN./MAX.      | - / 2.5 mm (0.098 in)                | -                | -                 | -                 |
| CENTRIFUGAL FORCE I          | 325 kN                               | 325 kN           | 335 kN            | 335 kN            |
| CENTRIFUGAL FORCE II         | 236 kN                               | 236 kN           | 260 kN            | 260 kN            |
| CENTRIF. FORCE ACE MIN./MAX. | - / 388/26 Hz                        | -                | -                 | -                 |

### ENGINE

|   |   |   |                                |                                 |
|---|---|---|--------------------------------|---------------------------------|
| MANUFACTURER                              | Cummins QSB 4.5-C160                      | Cummins QSB 4.5-C160                      | Cummins QSB 4.5-C160           | Cummins QSB 4.5-C160            |
| POWER ACCORDING TO ISO 3046-1             | 119 kW (160 HP)                           | 119 kW (160 HP)                           | 119 kW (160 HP)                | 119 kW (160 HP)                 |
| MAXIMUM TORQUE                            | 624/1500 Nm/rpm                           | 624/1500 Nm/rpm                           | 624/1500 Nm/rpm                | 624/1500 Nm/rpm                 |
| ENGINE COMPLIES WITH EMISSION REGULATIONS | EU Stage IIIA, U.S. EPA Tier 3            | EU Stage IIIB, U.S. EPA Tier 4i           | EU Stage IIIA, U.S. EPA Tier 3 | EU Stage IIIB, U.S. EPA Tier 4i |
| ROAD CONSTRUCTION TECHNOLOGY              | ACE <sup>pro</sup> / ACE <sup>force</sup> | ACE <sup>pro</sup> / ACE <sup>force</sup> | ACE <sup>force</sup>           | ACE <sup>force</sup>            |

### WEIGHT & OPERATING CHARACTERISTICS

|                             |                       |                       |                       |                       |
|-----------------------------|-----------------------|-----------------------|-----------------------|-----------------------|
| OPERATING WEIGHT            | 14 490 kg (31 940 lb) | 14 490 kg (31 940 lb) | 16 170 kg (35 650 lb) | 15 900 kg (35 050 lb) |
| MAXIMUM WEIGHT              | 16 670 kg (36 750 lb) | 16 650 kg (36 710 lb) | 17 190 kg (37 900 lb) | 16 860 kg (37 170 lb) |
| STATIC LINEAR LOAD          | -                     | -                     | -                     | -                     |
| MAX. TRANSPORT SPEED        | 10.1 km/h (6.28 MPH)  | 10.1 km/h (6.28 MPH)  | 10.1 km/h (6.28 MPH)  | 10.1 km/h (6.28 MPH)  |
| MAX. WORKING SPEED          | 4.6 km/h (2.86 MPH)   | 4.6 km/h (2.86 MPH)   | 4.6 km/h (2.86 MPH)   | 4.6 km/h (2.86 MPH)   |
| CLIMBING ABILITY            | 45 %                  | 45 %                  | 30 %                  | 50 %                  |
| TURNING RADIUS INNER (EDGE) | 3715 mm (146.3 in)    | 3715 mm (146.3 in)    | 3715 mm (146.3 in)    | 3715 mm (146.3 in)    |

# SPECIFICATIONS

## ARS SINGLE DRUM ROLLERS SMOOTH DRUM



|  | ARS 200 | ARS 200 | ARS 220 | ASC 220 |
|--|---------|---------|---------|---------|
|  | T3      | T4f     | T3      | T4f     |

### MISCELLANEOUS

|                    |                            |                            |                            |                            |
|--------------------|----------------------------|----------------------------|----------------------------|----------------------------|
| BRAKES OPERATING   | Hydrostatic                | Hydrostatic                | Hydrostatic                | Hydrostatic                |
| BRAKES PARKING     | Multiple-disc spring brake | Multiple-disc spring brake | Multiple-disc spring brake | Multiple-disc spring brake |
| BRAKES EMERGENCY   | Multiple-disc spring brake | Multiple-disc spring brake | Multiple-disc spring brake | Multiple-disc spring brake |
| FUEL TANK CAPACITY | 350 l (92,46 gal)          | 350 l (92,46 gal)          | 350 l (92,46 gal)          | 350 l (92,46 gal)          |
| VOLTAGE            | 24 V                       | 24 V                       | 24 V                       | 24 V                       |

### COMPACTION FORCES

|                              |                  |                  |                  |                  |
|------------------------------|------------------|------------------|------------------|------------------|
| FREQUENCY I                  | 34 Hz (2040 VPM) | 34 Hz (2040 VPM) | 34 Hz (2040 VPM) | 34 Hz (2040 VPM) |
| FREQUENCY II                 | 27 Hz (1620 VPM) | 27 Hz (1620 VPM) | 27 Hz (1620 VPM) | 27 Hz (1620 VPM) |
| FREQUENCY ACE MIN./MAX.      | -                | -                | -                | -                |
| AMPLITUDE I                  | 1 mm (0,039 in)  | 1 mm (0,039 in)  | 1 mm (0,039 in)  | 1 mm (0,039 in)  |
| AMPLITUDE II                 | 2 mm (0,079 in)  | 2 mm (0,079 in)  | 2 mm (0,079 in)  | 2 mm (0,079 in)  |
| AMPLITUDE ACE MIN./MAX.      | -                | -                | -                | -                |
| CENTRIFUGAL FORCE I          | 300 kN           | 300 kN           | 300 kN           | 300 kN           |
| CENTRIFUGAL FORCE II         | 375 kN           | 375 kN           | 375 kN           | 375 kN           |
| CENTRIF. FORCE ACE MIN./MAX. | -                | -                | -                | -                |

### ENGINE

|   | DEUTZ<br>TCD 6.1 L6               | DEUTZ<br>TCD 6.1 L6              | DEUTZ<br>TCD 6.1 L6               | DEUTZ<br>TCD 6.1 L6              |
|---|-----------------------------------|----------------------------------|-----------------------------------|----------------------------------|
| POWER ACCORDING TO ISO 3046-1             | 160 kW (215 HP)/2300 rpm          | 160 kW (215 HP)/2200 rpm         | 160 kW (215 HP)/2300 rpm          | 160 kW (215 HP)/2200 rpm         |
| MAXIMUM TORQUE                            | 694/1600 Nm/rpm                   | 694/1600 Nm/rpm                  | 694/1600 Nm/rpm                   | 694/1600 Nm/rpm                  |
| ENGINE COMPLIES WITH EMISSION REGULATIONS | EU Stage IIIA,<br>U.S. EPA Tier 3 | EU Stage IV,<br>U.S. EPA Tier 4f | EU Stage IIIA,<br>U.S. EPA Tier 3 | EU Stage IV,<br>U.S. EPA Tier 4f |
| ROAD CONSTRUCTION TECHNOLOGY              | ACE <sup>force</sup>              | ACE <sup>force</sup>             | ACE <sup>force</sup>              | ACE <sup>force</sup>             |

### WEIGHT & OPERATING CHARACTERISTICS

|                             |                             |                             |                             |                             |
|-----------------------------|-----------------------------|-----------------------------|-----------------------------|-----------------------------|
| OPERATING WEIGHT            | 19750 kg (43541,3 lb)       | 19750 kg (43541,3 lb)       | 21630 kg (47690 lb)         | 21930 kg (48350 lb)         |
| MAXIMUM WEIGHT              | 26000 kg (57320,2 lb)       | 26000 kg (57320,2 lb)       | 26000 kg (57320,2 lb)       | 26000 kg (57320,2 lb)       |
| STATIC LINEAR LOAD          | 58,6 kg/cm<br>(327,9 lb/in) | 58,6 kg/cm<br>(327,9 lb/in) | 66,9 kg/cm<br>(374,6 lb/in) | 66,9 kg/cm<br>(374,6 lb/in) |
| MAX. TRANSPORT SPEED        | 12 km/h (7,46 mph)          | 12 km/h (7,46 mph)          | 12 km/h (7,46 mph)          | 12 km/h (7,46 mph)          |
| MAX. WORKING SPEED          | 7 km/h (4,35 mph)           | 7 km/h (4,35 mph)           | 7 km/h (4,35 mph)           | 7 km/h (4,35 mph)           |
| CLIMBING ABILITY            | 55(50)%                     | 55(50)%                     | 55(50)%                     | 55(50)%                     |
| TURNING RADIUS INNER (EDGE) | 4370 mm (172 in)            | 4370 mm (172 in)            | 4370 mm (172 in)            | 4370 mm (172 in)            |

## ARS SINGLE DRUM ROLLERS PADFOOT DRUM



|  | ARS 200 | ARS 200 | ARS 220 | ARS 220 |
|--|---------|---------|---------|---------|
|  | T3      | T4f     | T3      | T4f     |

### MISCELLANEOUS

|                    |                            |                            |                            |                            |
|--------------------|----------------------------|----------------------------|----------------------------|----------------------------|
| BRAKES OPERATING   | Hydrostatic                | Hydrostatic                | Hydrostatic                | Hydrostatic                |
| BRAKES PARKING     | Multiple-disc spring brake | Multiple-disc spring brake | Multiple-disc spring brake | Multiple-disc spring brake |
| BRAKES EMERGENCY   | Multiple-disc spring brake | Multiple-disc spring brake | Multiple-disc spring brake | Multiple-disc spring brake |
| FUEL TANK CAPACITY | 350 l (92,46 gal)          | 350 l (92,46 gal)          | 350 l (92,46 gal)          | 350 l (92,46 gal)          |
| VOLTAGE            | 24 V                       | 24 V                       | 24 V                       | 24 V                       |

### COMPACTION FORCES

|                              |                  |                  |                  |                  |
|------------------------------|------------------|------------------|------------------|------------------|
| FREQUENCY I                  | 34 Hz (2040 VPM) | 34 Hz (2040 VPM) | 34 Hz (2040 VPM) | 34 Hz (2040 VPM) |
| FREQUENCY II                 | 27 Hz (1620 VPM) | 27 Hz (1620 VPM) | 27 Hz (1620 VPM) | 27 Hz (1620 VPM) |
| FREQUENCY ACE MIN./MAX.      | -                | -                | -                | -                |
| AMPLITUDE I                  | 1 mm (0,039 in)  | 1 mm (0,039 in)  | 1 mm (0,039 in)  | 1 mm (0,039 in)  |
| AMPLITUDE II                 | 2 mm (0,079 in)  | 2 mm (0,079 in)  | 2 mm (0,079 in)  | 2 mm (0,079 in)  |
| AMPLITUDE ACE MIN./MAX.      | -                | -                | -                | -                |
| CENTRIFUGAL FORCE I          | 300 kN           | 300 kN           | 300 kN           | 300 kN           |
| CENTRIFUGAL FORCE II         | 375 kN           | 375 kN           | 375 kN           | 375 kN           |
| CENTRIF. FORCE ACE MIN./MAX. | -                | -                | -                | -                |

### ENGINE

| MANUFACTURER                              | DEUTZ<br>TCD 6.1 L6               | DEUTZ<br>TCD 6.1 L6              | DEUTZ<br>TCD 6.1 L6               | DEUTZ<br>TCD 6.1 L6              |
|---|-----------------------------------|----------------------------------|-----------------------------------|----------------------------------|
| POWER ACCORDING TO ISO 3046-1             | 160 kW (215 HP)/2300 rpm          | 160 kW (215 HP)/2200 rpm         | 160 kW (215 HP)/2300 rpm          | 160 kW (215 HP)/2200 rpm         |
| MAXIMUM TORQUE                            | 694/1600 Nm/rpm                   | 694/1600 Nm/rpm                  | 694/1600 Nm/rpm                   | 694/1600 Nm/rpm                  |
| ENGINE COMPLIES WITH EMISSION REGULATIONS | EU Stage IIIA,<br>U.S. EPA Tier 3 | EU Stage IV,<br>U.S. EPA Tier 4f | EU Stage IIIA,<br>U.S. EPA Tier 3 | EU Stage IV,<br>U.S. EPA Tier 4f |
| ROAD CONSTRUCTION TECHNOLOGY              | ACE <sup>force</sup>              | ACE <sup>force</sup>             | ACE <sup>force</sup>              | ACE <sup>force</sup>             |

### WEIGHT & OPERATING CHARACTERISTICS

|                             |                       |                       |                       |                       |
|-----------------------------|-----------------------|-----------------------|-----------------------|-----------------------|
| OPERATING WEIGHT            | 19 875 kg (43817 lb)  | 19 875 kg (43817 lb)  | 21760 kg (47970 lb)   | 22060 kg (48630 lb)   |
| MAXIMUM WEIGHT              | 26000 kg (57320,2 lb) | 26000 kg (57320,2 lb) | 26000 kg (57320,2 lb) | 26000 kg (57320,2 lb) |
| STATIC LINEAR LOAD          | -                     | -                     | -                     | -                     |
| MAX. TRANSPORT SPEED        | 12 km/h (7,46 mph)    | 12 km/h (7,46 mph)    | 12 km/h (7,46 mph)    | 12 km/h (7,46 mph)    |
| MAX. WORKING SPEED          | 7 km/h (4,35 mph)     | 7 km/h (4,35 mph)     | 7 km/h (4,35 mph)     | 7 km/h (4,35 mph)     |
| CLIMBING ABILITY            | 55(50)%               | 55(50)%               | 55(50)%               | 55(50)%               |
| TURNING RADIUS INNER (EDGE) | 4370 mm (172 in)      | 4370 mm (172 in)      | 4370 mm (172 in)      | 4370 mm (172 in)      |



# TRAINING

## ENHANCE YOUR PERFORMANCE

The Ammann International Training Centre in the Czech Republic is our training headquarters. If you are not able to visit the International Training Centre, Ammann will bring the training to your business or even a jobsite of your choosing.

### MACHINE TRAINING MODULES

Modules help you organise your team's training efforts. For example, you can have comprehensive lessons that put you on the path to expertise regarding a single machine. Or, if you prefer, your crew can instead broaden its general knowledge. And if you want to become an expert on the entire product line, the modules can accommodate that, too.



#### MAIN COURSES

These are the most frequently requested lessons and focus on one machine line.

#### SUB COURSES

These courses focus on a single machine and typically run for 2 days, allowing a second (or even third) such course to be taken during a week at the training centre.

#### PRODUCT COURSES

Important information regarding Ammann compaction machines is at the core of these classes. The training includes correct operation and basic maintenance.

#### ADMINISTRATIVE COURSES

Participants in this training learn effective utilisation of warranty claims, spare parts purchase orders, training, requests for technical support and service tips. Those who take these classes will learn to use all Ammann technical publications and administration tools.

#### COMMISSIONING COURSES

In this training, participants learn maintenance and proper methods for organising a commissioning of Ammann compactors and asphalt pavers.

#### INTELLIGENT COMPACTION COURSES

Participants learn about the ACE<sup>force</sup>, ACE<sup>pro</sup> and ACE<sup>plus</sup> systems used in Ammann machines. Those who take the class will learn to properly operate, maintain, diagnose and repair ACE systems. The offerings include ACE System for Soil Compactors, which is focused on ASC rollers, and ACE System for Asphalt Compactors, which discusses systems on ARP 95, ARX 90 and ARX 110.

# SERVICE

## A NETWORK TO SUPPORT YOU

**No matter where you are, Ammann-trained technicians and parts are nearby. Ammann dealers provide well-trained service technicians who can help you, whether it's an emergency or time for preventive maintenance. The vast Ammann network ensures there is a nearby technician who understands your language and your technical needs. Parts availability and ease of ordering are always Ammann priorities.**

### HOTLINE SUPPORT

Ammann experts are ready to answer your technical questions 24 hours a day, seven days a week. The hotline team is highly trained and experienced. Representatives can talk you through the challenges – in various languages – to help keep your machine productive.

### SERVICE APP

The service app for Ammann machines impresses machine operators who are already benefiting from the advantages of the free application. The easy-to-use app provides machine operators working on site quick and uncomplicated access to machine documentation.

### SERVICE VIDEOS

Sometimes a video tells the story best. That's why you'll find a variety of service videos that walk you through service and maintenance processes.

### QR CODE

Many maintenance kits feature QR codes that link to videos with helpful demonstrations that walk you or your technician through the process. The videos tell the story without dialogue so customers anywhere in the world can understand.



# SPARE PARTS

You can only earn money when your equipment is working. That's why Ammann does everything possible to ensure you have the parts where and when you need them. Those efforts include easy online ordering to avoid confusion and enable tracking, and efficient logistics and availability to help parts reach you quickly.

## WEARING KITS

Some machines handle abrasive materials in demanding applications. While wear is inevitable, downtime can be limited. Wearing kits make replacement of these parts efficient and cost-effective. All the necessary parts – big and small – are in a single box to keep you organised and efficient and to ensure the machines are quickly back up and running.

## EMERGENCY KITS

Emergency kits prevent little frustrations from becoming bigger issues that can shut down a machine and even a jobsite. These kits include parts such as switches, fuses and valve coils that are simple and fast to change yet still can cause significant problems if not operating properly. The kits easily fit in the trunk or bed of a vehicle so they're on hand when needed. A crew-member with a bit of technical knowledge can handle this work on the jobsite. These repairs take 2 hours or less.



## MAINTENANCE KITS

Preventive maintenance is crucial to efficient operation and service life of machines. The easier the maintenance, the more likely it is to be completed. Maintenance kits make the upkeep simple. Parts associated with a particular maintenance process are in a single box with a single part number.

## BROCHURE WITH ALL KITS

We have a prospect with all kits, and their part numbers are available for you. Just contact your parts consultant and have a digital or hardcopy sent to you.







**“Service kits ensure that every part is there when you need it, while emergency kits prevent a little challenge from becoming a big one.”**

For additional product information  
and services please visit:  
**[www.ammann-group.com](http://www.ammann-group.com)**

